



ACURE | SINGLE-PHASE HYBRID INVERTER



USER MANUAL

SunC2-3.6LV01(W/B)
SunC2-5.0LV01(W/B)
SunC2-6.0LV01(W/B)
SunC2-7.0LV01(W/B)
SunC2-8.0LV01(W/B)

www.sunsynk.com
sales@sunsynk.com
customerservices@sunsynk.com

TABLE OF CONTENTS

LEGAL INFORMATION	3	Single-Phase Parallel Connection	42
Warning Notice System	3	Single-Phase Parallel on Three-Phase Grid	43
Qualified Personnel	3	Single-Phase Grid-Tied Connection	44
Proper Use of Sunsynk Products	3	OPERATION	45
Warranty	4	Switching ON/OFF	45
Trademarks	4	Display	45
Disclaimer of Liability	4	LED Indicators	45
Retention of This Manual	4	Function Buttons	45
SAFETY	4	LCD Operation Flow Chart	46
General Safety	4	Home	47
Symbols/Safety Signs	5	Menu	51
Safety Instructions	7	Setup Page	53
PRODUCT INTRODUCTION	8	Basic Setup	53
Key Features	8	Battery Setup	57
Product Overview	10	Battery Management System (BMS)	62
SunC2-(3.6/5.0/6.0)LV01(W/B)	10	Grid Setup	67
SunC2-(7.0/8.0)LV01(W/B)	11	System Mode	73
Product Size	12	Gen & Aux Load	74
Basic System Architecture	13	Advance	76
TECHNICAL SPECIFICATIONS	14	Smart Settings	81
INSTALLATION	16	Smart CT	83
Parts List	16	OPERATING MODES	84
Product Handling Requirements	17	Mode I: Basic	84
Installation Tools	17	Mode II: With Generator	84
Selecting the Mounting Area	18	Mode III: With Aux Load	85
Mounting the Inverter	20	Mode IV: AC Couple	85
Battery Connection	20	Mode V: Grid-Tied	87
Recommended DC Battery Protection	21	FAULT CODES	87
Function Port Definition	23	Debug	90
Lead-Acid Battery Temperature Sensor	25	COMMISSIONING	90
Wiring of PV Open Circuit Detection	26	Start-Up / Shutdown Procedure	90
Grid, Load, and Generator Connections	27	Inverter Commissioning Info	91
Recommended AC Surge Protector	30	GDFI Fault	91
PV Connection	31	MAINTENANCE	91
PV Module Selection	31	APPENDIX A	92
PV Module Wiring	32	APPENDIX B	92
PV Protection	34	APPENDIX C	92
CT Coil Connection	35	APPENDIX D	93
Meter Connection	36	APPENDIX E	93
CHINT Meter	36		
Eastron Meter	37		
Earth Connection (MANDATORY)	38		
Wiring System for Inverter	39		
Typical Application of Diesel Generator	41		

LEGAL INFORMATION

Warning Notice System

This manual includes important safety warnings that help ensure your safety and prevent damage to the equipment. These warnings are clearly identified with symbols, which are categorised according to the level of risk associated with each potential hazard. It is essential to read and adhere to these warnings carefully.



DANGER

Indicates an immediate hazard that, if not avoided, will result in serious injury or death. This is the highest level of risk.



WARNING

Indicates a potential hazard that could result in serious injury or death if not avoided. It is slightly less severe than "DANGER".



CAUTION

Highlights a potential hazard that could cause minor injuries or property damage if not avoided.



NOTICE

Provides helpful information that does not indicate any hazard.

Qualified Personnel

The Sunsynk Hybrid Inverter described in this manual must only be installed, operated, and maintained by qualified personnel. Qualified personnel are individuals who have received formal training in electrical systems and photovoltaic (PV) installations. They must be familiar with local electrical codes and regulations and capable of identifying potential risks associated with handling high-voltage equipment.

To ensure safe and efficient installation, Sunsynk strongly recommends engaging an installer approved by Sunsynk. These installers undergo specific training on Sunsynk products, ensuring they possess the necessary knowledge for secure and optimal installation, commissioning, and operation.

Improper installation or operation of the Sunsynk Hybrid Inverter by unqualified personnel may lead to personal injury, property damage, or voiding of the warranty.



WARNING

- Always use only components and accessories that are recommended or approved by Sunsynk.
- Follow all procedures outlined in this manual for transport, storage, installation, commissioning, operation, and maintenance.
- Ensure compliance with local and national safety codes and regulations.
- Operate the product only within the specified environmental conditions as outlined in this manual.

Proper Use of Sunsynk Products

The Sunsynk Hybrid Inverter is designed for use in energy storage and management in photovoltaic systems. To ensure safe and reliable operation, it is imperative to follow the instructions provided in this manual. Failure to do so may lead to unsafe operation, product damage, or invalidation of the warranty.

Warranty

For warranty details, please refer to the Warranty Statement supplied by Sunsynk.

Under our company's guidance, customers may return products for maintenance or replacement of equivalent value. Customers are responsible for shipping and associated costs. Any replaced or repaired product retains the remaining warranty period. If a product or component is replaced by the company during the warranty period, ownership rights of the replacement belong to the company.

Factory warranty does not cover damages resulting from:

- Transportation mishaps
- Incorrect installation or commissioning
- Failure to follow operation, installation, or maintenance instructions
- Attempts to modify, alter, or repair products
- Incorrect usage or operation
- Inadequate equipment ventilation
- Non-compliance with safety standards or regulations
- Natural disasters or force majeure (e.g., floods, lightning, overvoltage, storms, fires, etc.)

Normal wear or minor failures that do not affect product functionality are not considered defects. External scratches, stains, or mechanical wear do not indicate product defects.

Trademarks

All names and logos identified in this document are the property of Sunsynk. Unauthorised use of Sunsynk trademarks is strictly prohibited. All other trademarks mentioned remain the property of their respective owners.

Disclaimer of Liability

This document is the property of Sunsynk. Any reproduction, modification, or distribution of this manual without prior written consent from Sunsynk is strictly prohibited.

The content of this manual has been thoroughly reviewed for accuracy and is consistent with the product described. However, due to ongoing product improvements and updates, Sunsynk cannot guarantee complete consistency. Any necessary corrections or updates will be included in subsequent editions of this manual.

Retention of This Manual

This manual contains essential information for the assembly, installation, commissioning, and maintenance of the Sunsynk Hybrid Inverter. It must be retained for future reference and made accessible to all qualified personnel involved in the operation and maintenance of this product.













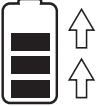

SAFETY

General Safety

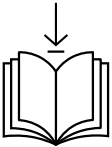
- This device must be used only as described in this manual and in compliance with all local, regional, and national laws and regulations. Ensure that installation, operation, maintenance, and repair are only performed by qualified personnel who have read and fully understood this manual. The manual should be passed to any third party who handles the device.
- DO NOT allow minors, untrained personnel, or individuals with physical or mental impairments to operate or maintain this device. Only trained individuals should interact with the device during installation, operation, or maintenance. If untrained individuals are near the device during operation, they must be informed of potential hazards and given proper instructions to avoid injury.
- Periodically inspect the device for any signs of damage or wear. Always ensure that all connections are secure and that there are no exposed wires or components that may pose a risk of electric shock.

Symbols/Safety Signs

Symbol	Description	Symbol	Description
	Risk of danger.		Warning: Hot surface.
	Risk of electric shock. DO NOT touch the terminal or remove the shell within 5 minutes after disconnecting all power.		The battery is heavy and can cause injury if not handled safely.
	This product's batteries contain an explosive, self-reactive material that could blow up when heated.		Do not disassemble or alter the battery in any way. Do not strike or puncture the battery.
	Do not place near open fire or incinerate. Do not use near heaters or hot temperature sources.		ONLY qualified personnel should install or perform maintenance work on the units.
	Be careful when touching the inverter. It is an electrical product with risk of electric shock and heating.		Warranty void if seal is broken.
	Do not step, stand, or climb on this surface.		Avoid unsuitable shoes for installing and operating the inverter.
	Do not step or put any objects onto the battery.		Do not drop, deform, or impact the battery.
	Single-phase.		Three-phase.
	Protective conductor terminal or earth ground terminal.		Rechargeable.
	Do not submerge the battery in water or expose it to moisture or liquid.		Keep out of reach of children, animals, and insects.
	Do not expose the product to sunlight.		Inverter DC to AC.
	Li-ion battery.		Net weight in kilograms.
	BATTERY INPUT Battery Discharge Voltage, Battery Discharge Current, Input Voltage Type, Battery Discharge Power.		PV INPUT PV Input Voltage, Number of MPPT's, MPPT Input Current & Max PV ISC.

Symbol	Description	Symbol	Description
	Direct current.		Indicates that this product is recyclable.
	AC OUTPUT Output Voltage, Input Voltage Type, Ac Output Rated Current, Max AC Current, Output Frequency, Max AC ISC, Power Factor & AC Output Rated Power.		CONTINUOUS OUTPUT CURRENT Maximum Continuous Output Current, Output Frequency and Voltage, & AUX (programmable AC output on battery SOC).
	Charging.		Discharging.
	Follow the indicated temperatures.		TEMPERATURE Ambient, Min & Max.
	MANUAL DOWNLOAD Download the latest version of the instruction manual by scanning the QR code.		WARRANTY REGISTRATION Scan the QR code to access our website and sign up for the manufacturer's warranty.
	Do not dispose the device, accessories, and packaging with regular waste. Follow local ordinances or contact the manufacturer for disposal guidance.		Refer to the operating instructions. Contact the supplier within 24 hours if there is anything wrong. In case of leakage contact with eyes or skin, immediately clean with water and seek help from a doctor.
	CE mark is attached to the solar inverter to verify that the unit follows the provisions of the European Low Voltage and EMC Directives.		The UKCA marking is used for products placed on the market in Great Britain (England, Scotland and Wales). The UKCA marking applies to most products for which the CE marking could be used.

Safety Instructions

This section provides essential safety and operational guidelines. Please read carefully and keep this manual for future reference.



DANGER

Electric Shock Hazard from Live Components or DC Cables

- DC cables connected to a battery or PV module may be live, posing a severe electric shock risk.
- Disconnect the system from all voltage sources and ensure it cannot be reconnected before performing any work.
- Do not touch non-insulated parts or cables. Always wear personal protective equipment (PPE).

Electric Shock Risk from Touching an Ungrounded PV Module or Array Frame

- Touching ungrounded PV modules or array frames may result in fatal electric shock.
- Ground the PV modules, array frame, and all electrically conductive surfaces properly. Follow local safety regulations to ensure safety.

Risk of Electric Shock Due to Ground Fault

- Ground faults can leave parts of the system live, creating a significant electric shock risk.
- Disconnect the system from all voltage sources and wait for five minutes before touching any parts of the system.
- Only touch the cables by their insulated parts to avoid contact with live conductors.



WARNING

Fire or Explosion Risk from Charging Fully Discharged Batteries

- Never charge a fully discharged battery. Attempting to do so may cause fire or explosion.
- Verify the battery's charge status before commissioning the inverter. If the battery is fully discharged, contact the manufacturer for further guidance.

Electric Shock Risk Due to Missing Surge Protection in Case of Overvoltage

- Ensure surge protection devices are in place to prevent damage from overvoltage (e.g., lightning).
- Verify that all devices in the system, including the inverter and battery, are connected to the surge protection network before use.

Electric Shock Risk from Measuring Device Damage Due to Overvoltage

- Use measuring devices only with voltage ranges suitable for the inverter's output and the battery's maximum DC voltage.
- Do not use devices not rated for the inverter's voltage range as this may result in electric shock.



CAUTION

Burn Hazard from Hot Inverter Parts

- Inverter housing and internal components can become hot during operation.
- Avoid touching the inverter during operation. Wait for the unit to cool down before handling.

Risk of System Malfunction Due to Incorrect Environmental Conditions

- Ensure the inverter is installed in a dry, well-ventilated environment, away from excessive moisture or dust.
- Ensure the ambient temperature remains within the specified range to prevent performance issues or malfunctions.



NOTICE

Damage Due to Sand, Dust, and Moisture Ingress

- Protect the inverter from exposure to dust, sand, or moisture to prevent system damage.
- Install the inverter in a clean, dry location to ensure reliable performance and long service life.

Risk of Damage in Subfreezing Conditions

- Do not operate the inverter if the temperature is below -5°C (23°F).
- Remove ice from the inverter's seal before opening in freezing conditions to avoid damaging the enclosure.

Risk of Damage Due to Electrostatic Discharge (ESD)

- Always ground yourself before handling sensitive components of the inverter to avoid damage caused by electrostatic discharge.
- Avoid direct contact with the inverter's internal components without proper grounding.

DO NOT Dispose of this Product with Household Waste!

- Electrical devices must be disposed of in accordance with local electronic waste disposal regulations. If you have any questions, please contact your supplier. In some cases, the supplier can arrange proper disposal.

PRODUCT INTRODUCTION

The Sunsynk 3.6/5/7/8kW Hybrid Inverter is a multifunctional energy solution that integrates an inverter, solar charger, and battery charger into a single compact and efficient unit. Designed to provide uninterrupted power support, it enables seamless integration of solar energy generation, battery storage, and grid connection, making it an ideal solution for residential and small commercial solar energy systems.

This versatile inverter supports both grid-tied and off-grid configurations, offering flexibility in energy management. It optimises solar energy use by allowing users to store surplus power for later use, thereby reducing dependence on the grid and lowering electricity costs.

Key Features

INTERACTIVE & USER-FRIENDLY:

- Colourful touch LCD display: Easy-to-understand, interactive display with real-time monitoring of system performance and power flow.
- Visibility: Provides remote monitoring capabilities through Wi-Fi Ethernet and Bluetooth, allowing users to track system data from anywhere.
- Visual power flow screen: Displays the power flow between the solar panels, battery, inverter, and grid in a clear and simple visual format.
- Smart settable 3-stage MPPT charging: Optimises battery charging with a smart 3-stage MPPT (Maximum Power Point Tracking) charging system to ensure efficient energy use and battery health.

COMPATIBLE & VERSATILE:

- Supports multiple power sources: Compatible with main electrical grid voltages, power generators, and wind turbines, providing flexibility for various energy sources.
- Pure sine-wave output: Delivers a 220 V single-phase, pure sine-wave output, ensuring smooth operation of sensitive electronics and appliances.
- Self-consumption & grid feed-in: Supports both self-consumption (using generated solar energy) and feeding excess power back into the grid, reducing energy bills and increasing efficiency.

- Auto restart on AC recovery: Automatically restarts when AC power is restored, ensuring uninterrupted power supply after grid failures.
- Auto earth bonding feature: Features an auto earth bond function (via relay) for safe operation, automatically establishing an earth connection as required.
- LoRa communication: Allows seamless wireless connectivity with up to 10 Sunsynk Smartlynk devices and 2 CT coils—delivering smarter, scalable system control with zero compromise on range or reliability.

CONFIGURABLE & FLEXIBLE:

- Fully programmable controller: Offers full programmability for battery/grid supply priority, enabling users to control energy flow based on personal preferences.
- Multiple operation modes: Select from on-grid, off-grid, or UPS modes, allowing flexible use in various environments such as homes, offices, and remote locations.
- Configurable battery charging: Adjust charging current/voltage settings via the LCD display based on specific application requirements, ensuring the optimal charging profile for different battery types.
- AC/Solar/Generator charger priority: Customise charging priority settings for solar, AC, or generator inputs via the LCD for maximum flexibility.

SECURE & RELIABLE:

- Overload, over-temperature, and short-circuit protection: Built-in protections to prevent damage to the inverter and connected components, ensuring long-term reliability.
- Smart battery charger design: Optimised charging design to protect the battery from overcharging and undercharging, extending battery life and enhancing performance.
- Power limiting function: Prevents excess power overflow to the grid, ensuring compliance with local regulations and optimising energy use.

APPLICATIONS:

- Marine (vessel power management): Ideal for managing power on boats and ships, offering a reliable source of energy for marine systems.
- Power shedding (home/office/factory): Perfect for applications requiring power shedding, such as in homes, offices, and factories, to manage energy consumption and ensure availability.
- UPS (fuel-saving systems): In UPS systems, it minimises fuel consumption by efficiently managing battery and grid power usage, reducing operational costs.
- Remote locations: Suitable for off-grid applications in remote areas, integrating solar, battery, and generator power to provide reliable energy in isolated locations.
- Construction sites & military locations: Provides temporary power solutions for building sites, military installations, and other mobile or temporary infrastructure.
- Telecommunications: Offers reliable backup power for telecommunication towers, ensuring continuous operation even during power outages.

ADDITIONAL FEATURES:

- Supports parallel connections: Can connect up to 16 inverters in parallel for both on-grid and off-grid applications, supporting large-scale installations and multiple battery banks.
- Max charging/discharging current: 90 A for 3.6 kW model, 120 A for 5 kW model, 135 A for 6 kW model, 175 A for 7 kW model, and 190 A for 8 kW model . Provides efficient energy storage and retrieval for both models.
- 6 time periods for battery charging/discharging: Users can set specific time periods for optimised charging and discharging cycles, maximising battery life and operational efficiency.

Product Overview

SunC2-(3.6/5.0/6.0)LV01(W/B)

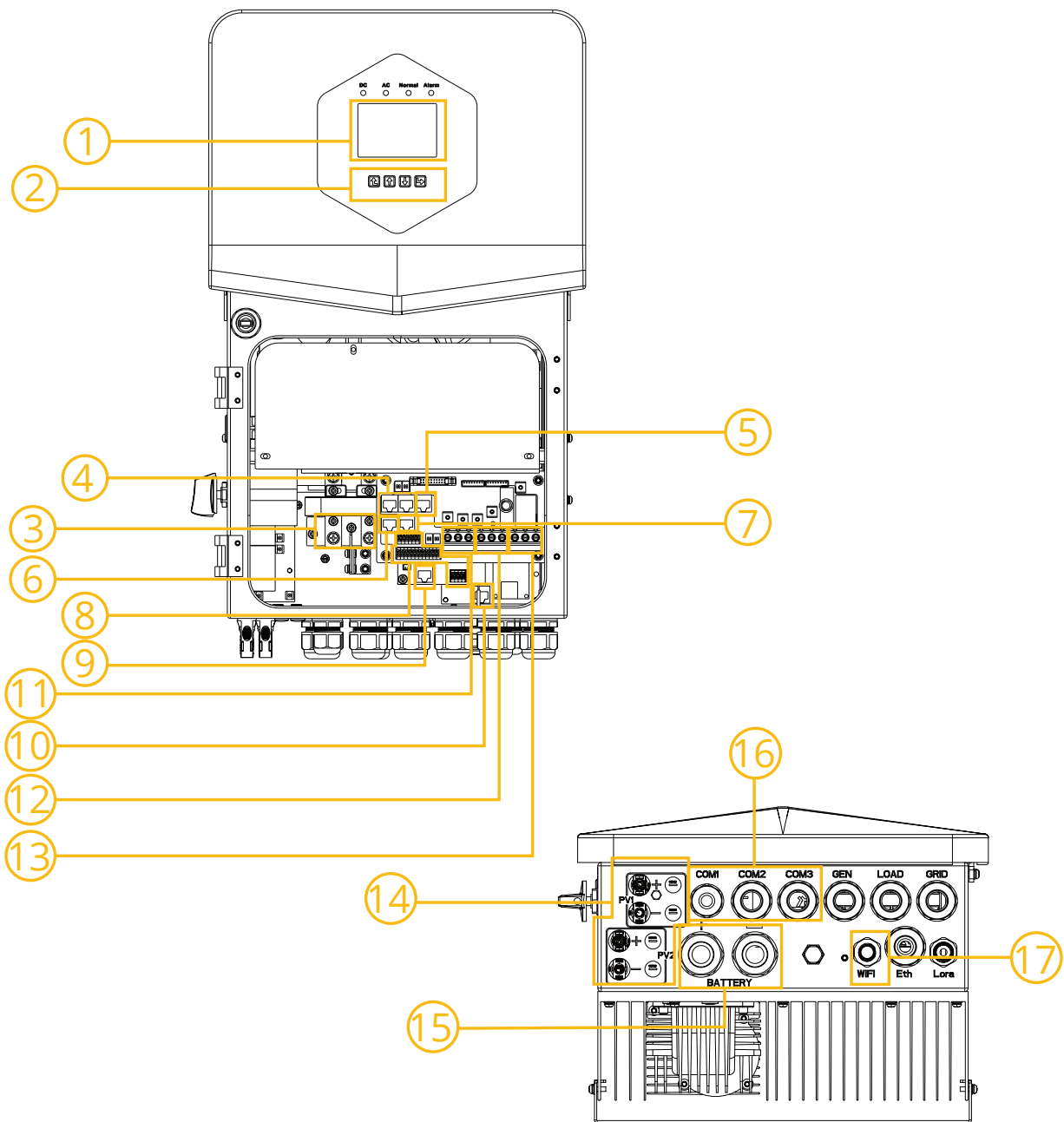

- | | | |
|-----------------------------|---------------------|----------------------------|
| 1. LCD Display | 7. Modbus Port | 13. Grid |
| 2. Function Buttons | 8. Function Port | 14. PV Input with Two MPPT |
| 3. Battery Input Connectors | 9. DRMs Port | 15. Battery |
| 4. Parallel Port | 10. LoRa Port | 16. Temperature Sensor |
| 5. BMS 485/CAN Port | 11. Generator Input | 17. Wi-Fi Interface |
| 6. RS485/Meter Port | 12. Load | |

SunC2-(7.0/8.0)LV01(W/B)

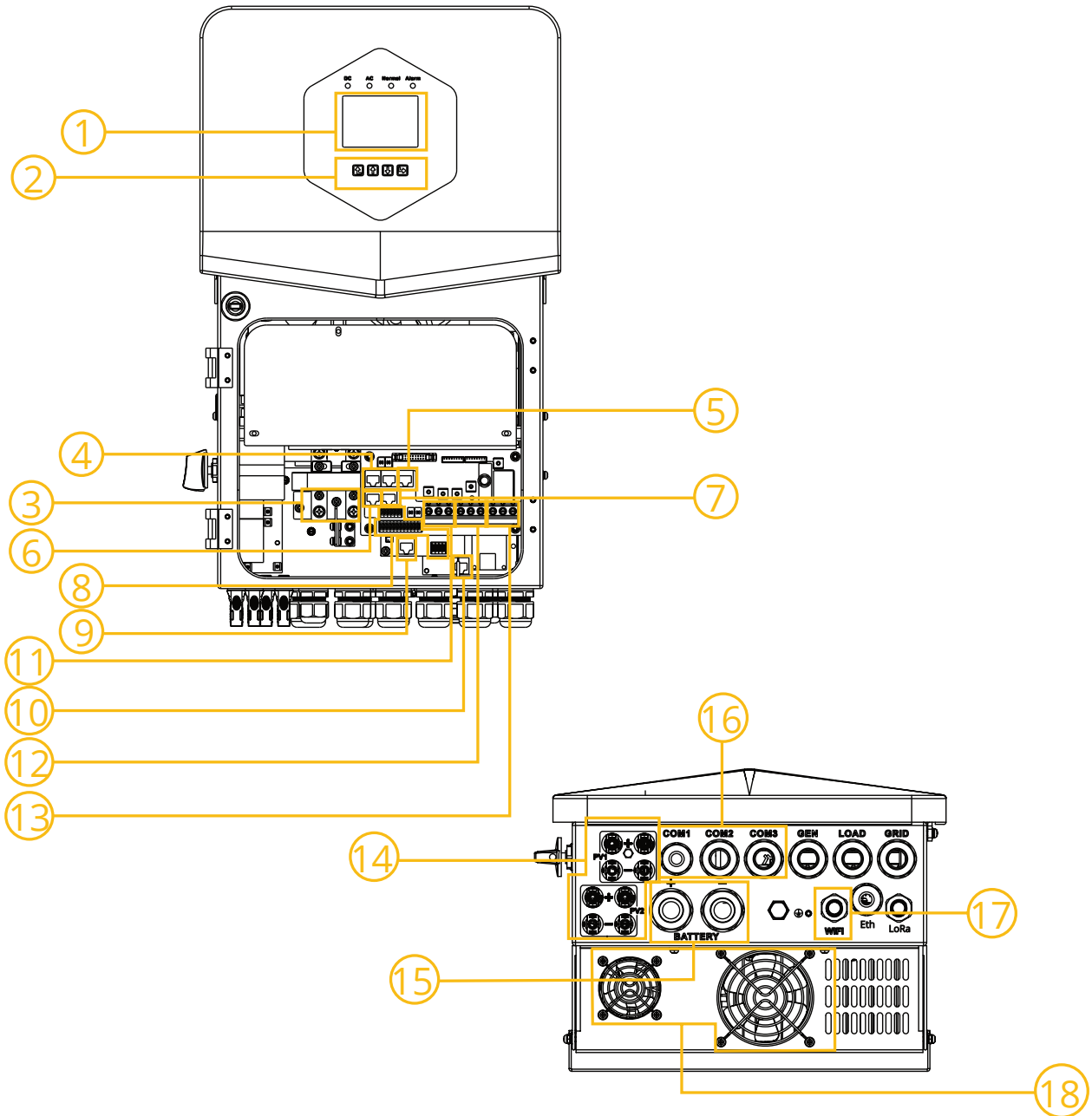

- | | | |
|-----------------------------|---------------------|----------------------------|
| 1. LCD Display | 7. Modbus Port | 13. Grid |
| 2. Function Buttons | 8. Function Port | 14. PV Input with Two MPPT |
| 3. Battery Input Connectors | 9. DRMs Port | 15. Battery |
| 4. Parallel Port | 10. LoRa Port | 16. Temperature Sensor |
| 5. BMS 485/CAN Port | 11. Generator Input | 17. Wi-Fi Interface |
| 6. RS485/Meter Port | 12. Load | 18. Fan |

Product Size

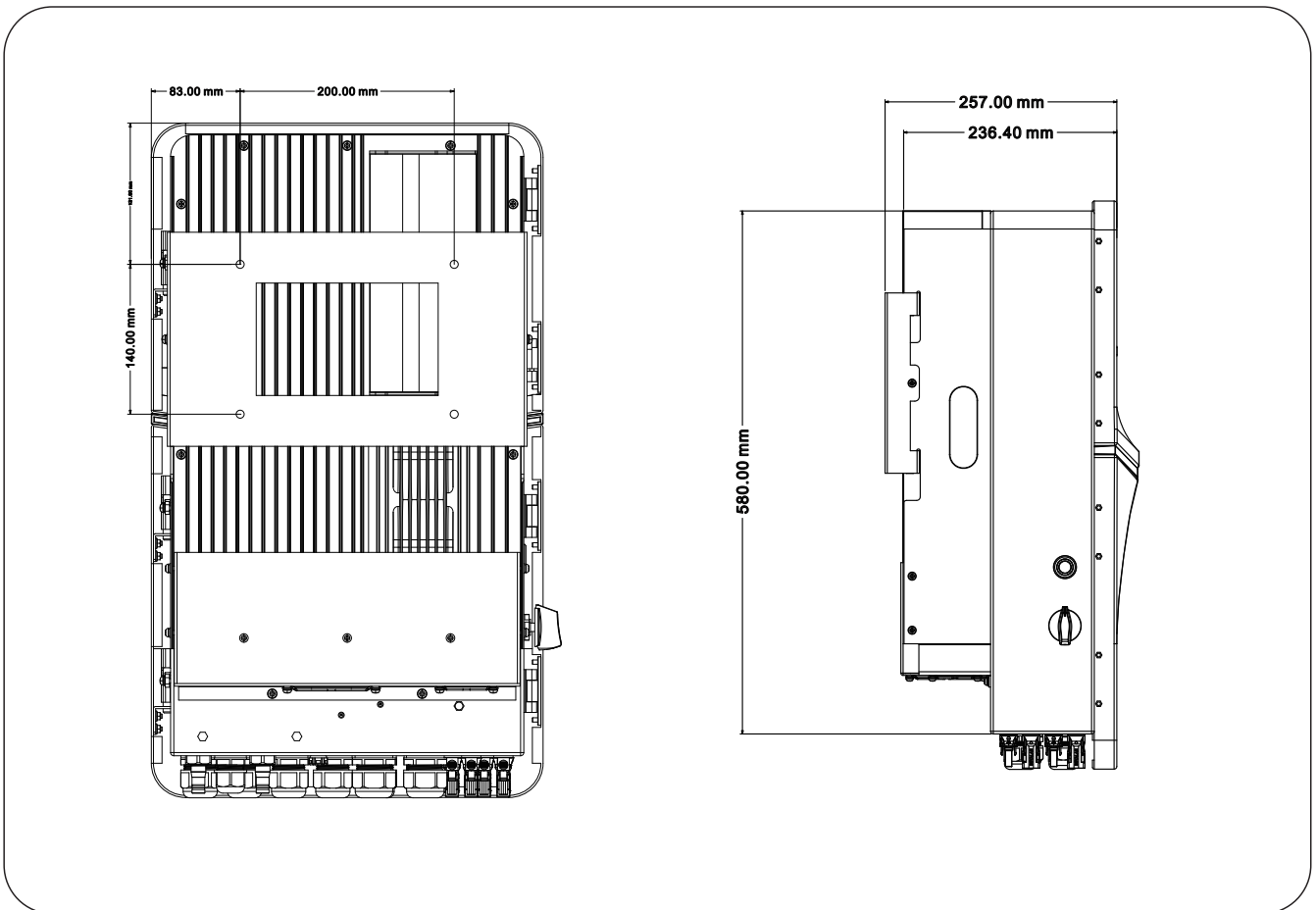
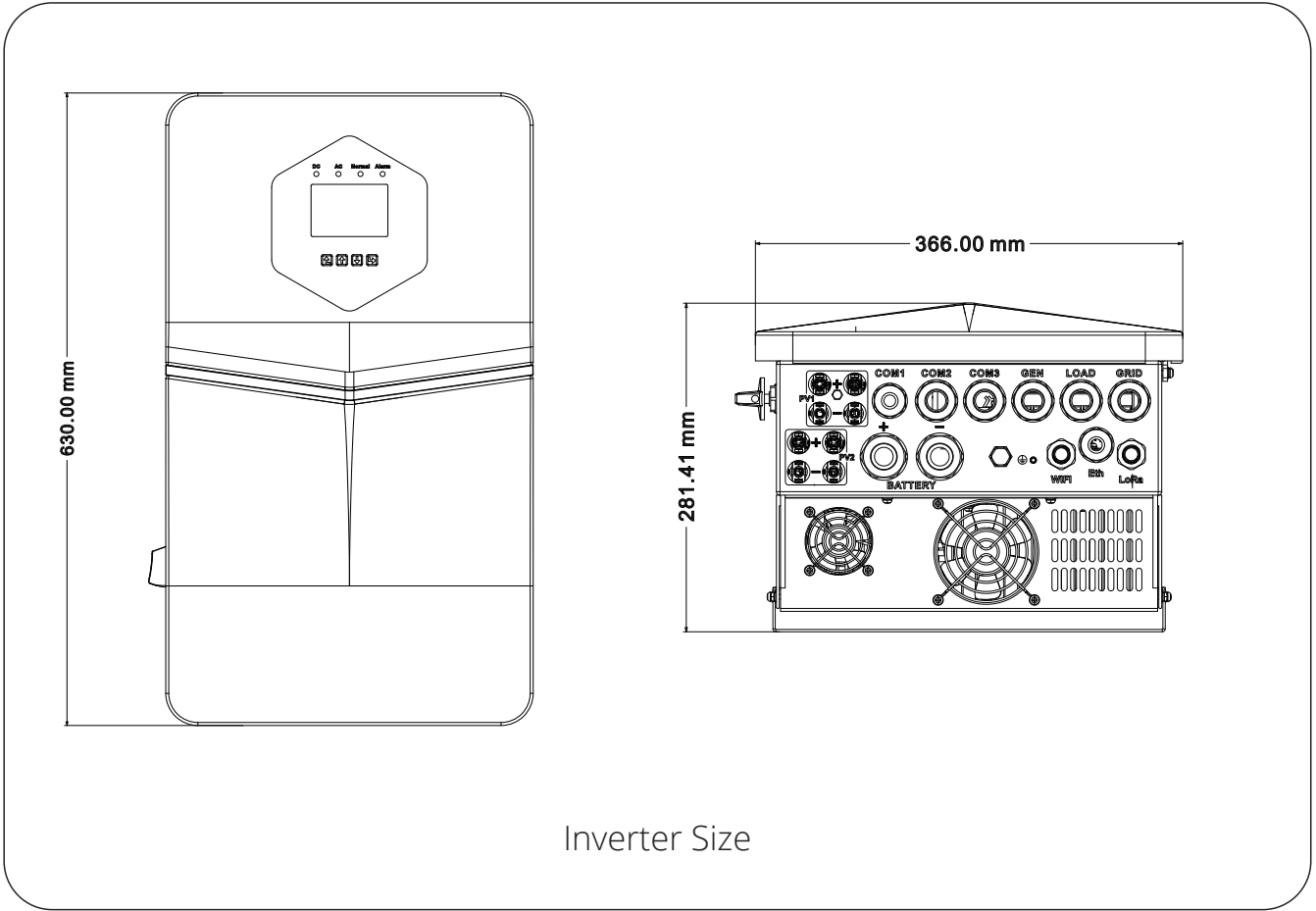

Basic System Architecture

The diagram below illustrates a typical configuration of the Sunsynk Acure Hybrid Inverter within a complete operational system. The following key components are essential for optimal performance and energy management:

- PV Modules (Solar Panels): Capture sunlight and convert it into DC (direct current) power.
- Sunsynk Hybrid Inverter: Converts the DC power from the solar panels and battery into AC (alternating current) power for household or business use.
- Battery: Stores excess solar energy for use when sunlight is insufficient (e.g., at night or during cloudy days).
- Generator or Utility Grid: Provides power to the system when solar energy and stored battery power are unavailable. It can also serve as a backup power source.
- Grid-Connected Load (AC Loads): Powers everyday household or business appliances such as lights, refrigerators, and other electrical devices.
- Backup Load: Ensures essential appliances (e.g., medical equipment, emergency lighting) continue to operate during power outages.
- Smart Load: Enables efficient energy use by intelligently prioritising or controlling the use of appliances based on available power.

In addition, the system integrates the following features for flexibility and smart operation:

- Wi-Fi/BT: Allows remote monitoring of the inverter's performance via a mobile app or cloud-based services.
- Automatic Transfer Switch (ATS): Automatically switches between power sources (e.g., grid, generator, and battery) to ensure a continuous power supply without interruption.

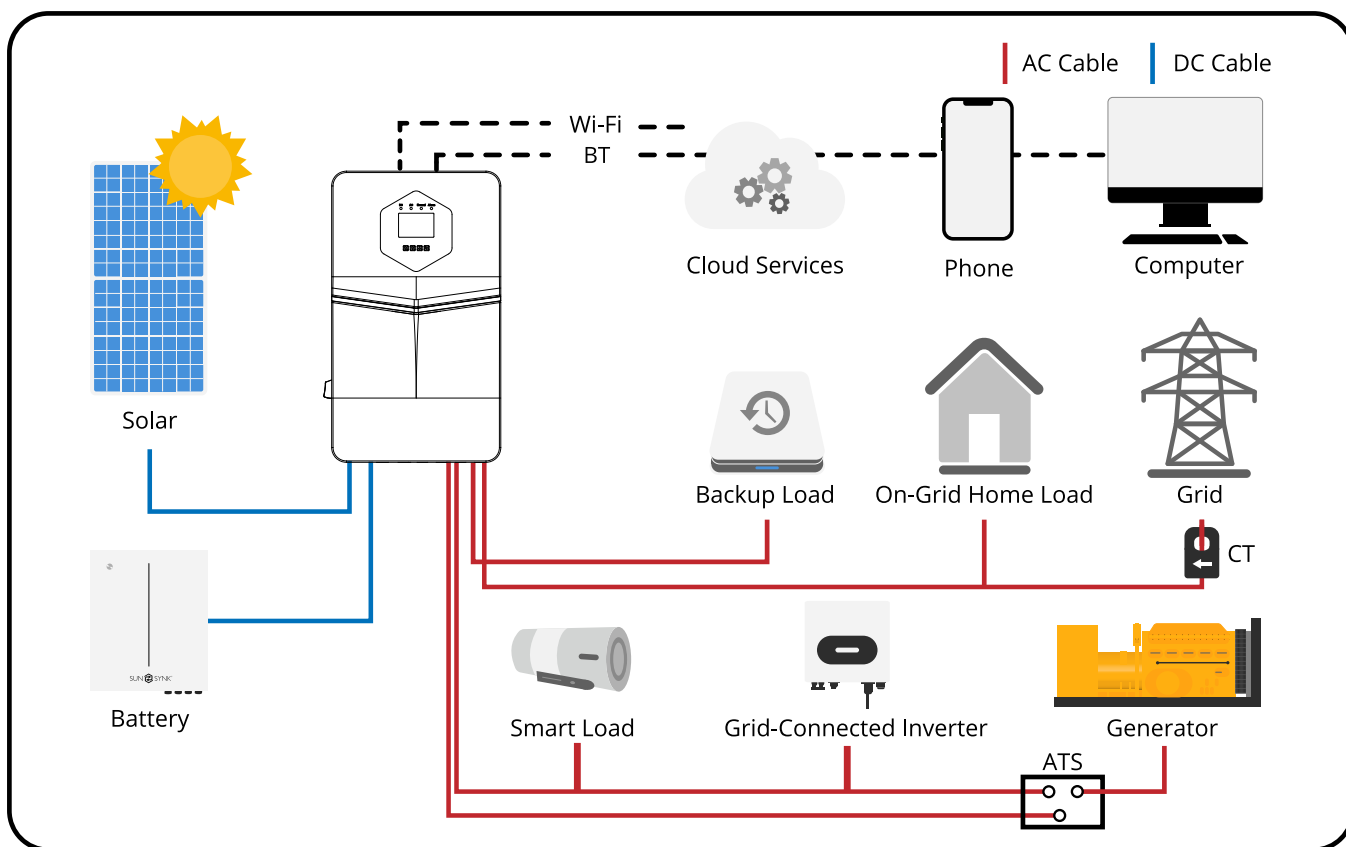

TECHNICAL SPECIFICATIONS

Model	SunC2-3.6LV01(W/B)	SunC2-5.0LV01(W/B)	SunC2-6.0LV01(W/B)	SunC2-7.0LV01(W/B)	SunC2-8.0LV01(W/B)
Battery Input Data					
Battery Type	Lead-acid or Lithium-ion				
Battery Voltage Range	40-60V				
Max. Charging Current	90A	120A	135A	175A	190A
Max. Discharging Current	90A	120A	135A	175A	190A
Charging Strategy for Li-ion Battery	Self-adaption to BMS				
Number of Battery Input	1				
PV String Input Data					
Max. PV Access Power	7200W	10000W	12000W	14000W	16000W
Max. PV Input Power	5760W	8000W	9600W	11200W	12800W
Max. PV Input Voltage	500V				
Start-up Voltage	125V				
MPPT Voltage Range	150-425V				
Rated PV Input Voltage	370V				
Max. Operating PV Input Current	18+18A			32+32A	
Max. Input Short-Circuit Current	27+27A			48+48A	
No. of MPP Trackers / No. of Strings MPP Tracker	2/1+1			2/2+2	
AC Input/Output Data					
Rated AC Input/Output Active Power	3600W	5000W	6000W	7000W	8000W
Max. AC Input/Output Apparent Power	3960VA	5500VA	6600W	7700VA	8800VA
Peak Power (off-grid)	2 times of rated power, 10s				
Rated AC Input/Output Current	16.4/15.7A	22.8/21.8A	27.3/26.1	31.9/30.5A	36.4/34.8A
Max. AC Input/Output Current	18/17.3A	25/24A	30/28.7	35/33.5A	40/38.3A
Max. Continuous AC Passthrough (Grid to Load)	35A		40A	50A	
Rated Input/Output Voltage/Range	220V/230V 0.85Un-1.1Un				
Grid Connection Form	L+N+PE				
Rated Input/Output Grid Frequency/Range	50/45-55Hz 60/55-65Hz				
Power Factor Adjustment Range	0.8 leading-0.8 lagging				
Total Current Harmonic Distortion THDi	<3% (of nominal power)				
DC Injection Current	<0.5% In				
Efficiency					
Max. Efficiency	97.6%				
Euro Efficiency	96.5%				
MPPT Efficiency	>99%				
Protection					
Integrated	DC Polarity Reverse Connection Protection, AC Output Overcurrent Protection, Thermal Protection, AC Output Overvoltage Protection, AC Output Short Circuit Protection, DC Component Monitoring, Overvoltage Load Drop Protection, Ground Fault Current Monitoring, Arc Fault Circuit Interrupter (optional), Power Network Monitoring, Island Protection Monitoring, Earth Fault Detection, DC Input Switch, DC Terminal Insulation Impedance Monitoring, Residual Current (RCD) Detection, Surge protection level				
Surge Protection Level	TYPE II(DC), TYPE II(AC)				
Interface					
Display	LCD+LED				
Communication Interface	RS485/RS232/CAN				
Monitor Mode	GPRS/WIFI/Bluetooth/4G/LAN(optional)				

General Data

Operating Temperature Range	-40 to +60°C, >45°C Derating
Permissible Ambient Humidity	0-100%
Permissible Altitude	2000m
Noise	<30dB
Ingress Protection (IP) Rating	IP65
Inverter Topology	Non-Isolated
Over Voltage Category	OVC II(DC), OVC III(AC)
Cabinet Size (WxHxD)	366x630x281.41mm (Excluding Connectors and Brackets)
Weight	27.1kg
Type of Cooling	Intelligent Air Cooling
Warranty	5 years (10 years when installed with a Sunsynk battery)
Grid Regulation	G98/G99, NRS 097-2-1, EN 50549-1
Safety / EMC Standard	IEC/EN 61000-6-1/2/3/4, IEC/EN 62109-1, IEC/EN 62109-2



NOTICE







Safe Transport and Handling of the Inverter

When transporting the equipment, always use its original packaging and keep it intact as a complete unit. Store the product in a dry environment, avoiding direct sunlight, and maintain a temperature range between -40°C and 60°C. As the equipment can be quite heavy, always consider its total weight when moving, transporting, or installing it, ensuring that the installation site has adequate load-bearing capacity. Transporting and installing the inverter should only be carried out by qualified personnel.

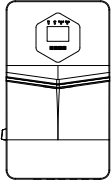
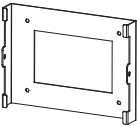
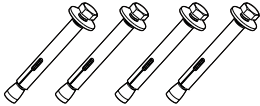
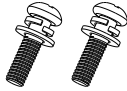
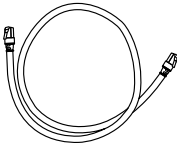
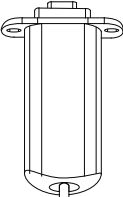
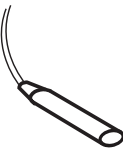
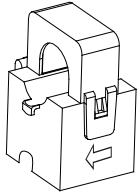
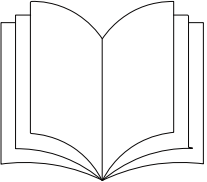
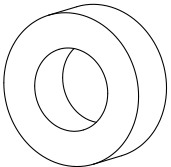
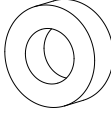
INSTALLATION

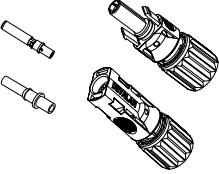
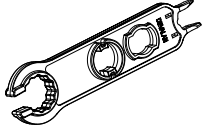
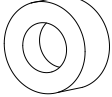
Parts List

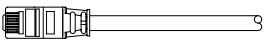
Check the equipment before installation. Please make sure nothing is damaged in the package. You should have received the items in the following package:

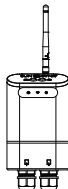
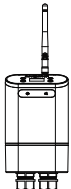
 <p>Hybrid inverter x1</p>	 <p>Wall mounting bracket x1</p>	 <p>Stainless steel anti-collision bolt M6*60 x4</p>	 <p>Stainless steel mounting screws M4*12 x4</p>
 <p>Parallel communication cable x1</p>	 <p>Datalogger (optional) x1</p>	 <p>Battery temperature sensor x1</p>	 <p>Sensor clamp x1</p>
 <p>User manual x1</p>	<p>1</p>  <p>Magnetic ring for battery x1</p>	<p>2,9</p>  <p>Magnetic ring for BMS and Meter communication cable x2</p>	<p>6,7,8</p>  <p>Magnetic ring for AC wires x3</p>
 <p>DC+/DC- plug connectors including metal terminal xN</p>	 <p>Solar photovoltaic connector special spanner x1</p>	<p>3,5</p>  <p>Magnetic ring x2</p>	<p>4</p>  <p>Magnetic ring for CT's output wire x1</p>
 <p>DRM connector x1</p>	 <p>Stainless steel mounting screws M4*8 x2</p>	 <p>Sunsynk Smartlynk (optional) x10</p>	 <p>Sunsynk Wireless CT (optional) x2</p>

Product Handling Requirements

Lift the inverter out of the packing box and transport it to the designated installation location.

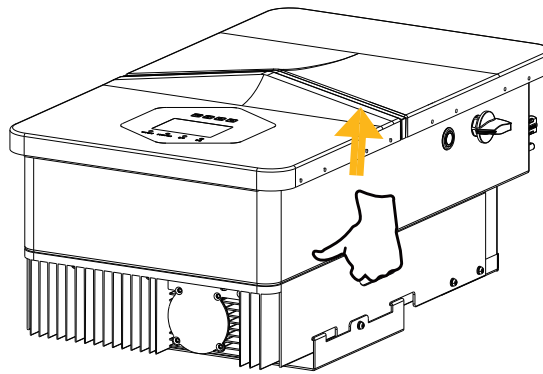

Transport



WARNING

Improper handling can result in personal injury!

- Ensure an adequate number of personnel are present to lift the inverter safely, considering its weight. Installation personnel should wear protective gear, including anti-impact shoes and gloves.
- Avoid placing the inverter directly on hard ground, as this can damage its metal enclosure. Use protective materials like sponge pads or foam cushions underneath the inverter.
- Move the inverter with one or two people or utilize appropriate transport tools.
- When moving the inverter, always hold it by the handles. Do not attempt to move it by holding the terminals.

Installation Tools

Installation tools can include the following recommended items. Additionally, utilize any other auxiliary tools available on-site.

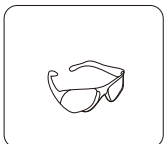

Protective goggles

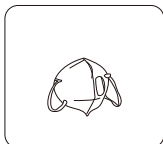

Earplugs

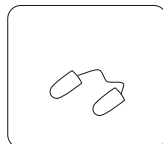

Anti-dust mask

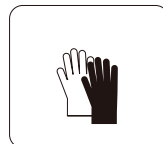

Work gloves



Work shoes

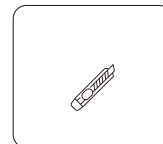

Utility Knife

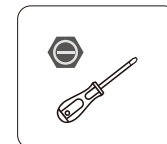

Slotted screwdriver

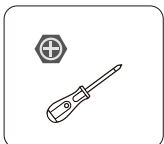

Cross screwdriver

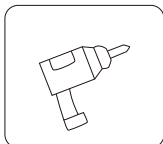

Percussion drill

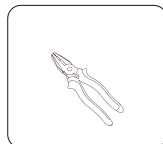

Pliers

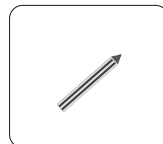

Marker

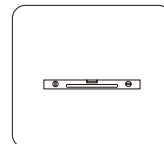

Level

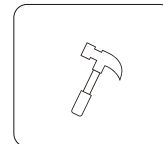

Rubber hammer

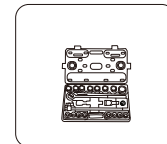

Socket wrenches set

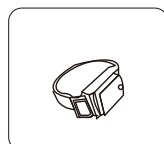

Anti-static wrist strap

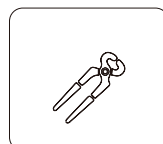

Wire cutter

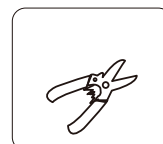

Wire stripper

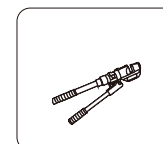

Hydraulic pliers

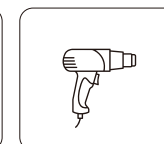

Heat gun

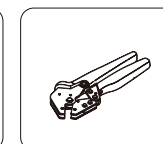

Crimping tool4-6mm²

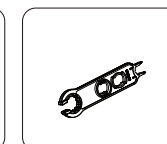

Solar connector wrench

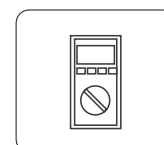

Multimeter ≥ 1100 Vdc

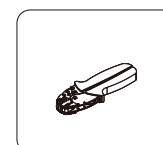

RJ45 crimping plier

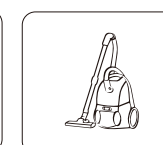

Cleaner

Selecting the Mounting Area

The Sunsynk Hybrid Inverter is rated IP65 and is suitable for outdoor installation. However, do not install the inverter in the following locations:

- Coastal or high-salt areas: Salt can corrode metal parts and allow moisture to enter the unit.
- Kitchens or oily environments: Oil mist, steam, or splashed liquids can damage plastic parts and compromise the inverter's sealing.
- Chemically active areas: Avoid areas with sulphuric gases, chlorine, acids, or alkalis, which can corrode internal copper components and reduce electrical conductivity.
- Flammable or explosive atmospheres: Do not install near areas with a risk of gas leaks, flammable dust, paint thinners, or volatile chemicals.
- Enclosed gas-prone spaces: Avoid spaces where leaked gases may collect around the inverter, as this presents a fire risk.
- Animal-exposed areas: Do not install where animals may urinate or where ammonia is present, as this can damage internal components.
- High altitude: Installation above 2,000 metres (sea level) is not recommended due to reduced cooling efficiency and potential derating.
- Excessive humidity: Do not install in environments with humidity levels above 95%.
- Poor air circulation: Ensure there is sufficient ventilation to allow for proper cooling.



DANGER

Risk of Fire or Explosion

- Despite careful construction, electrical devices can cause fires, resulting in death or serious injury.
- Do not mount the system in areas containing highly flammable materials or gases.
- Do not mount the system in potentially explosive atmospheres.



NOTICE

Avoid direct sunlight, rain, or snow accumulation during installation and operation. These environmental factors may reduce the inverter's efficiency and lifespan.

Before connecting any wires, remove the inverter's metal cover by loosening the screws, as shown in the diagram below.

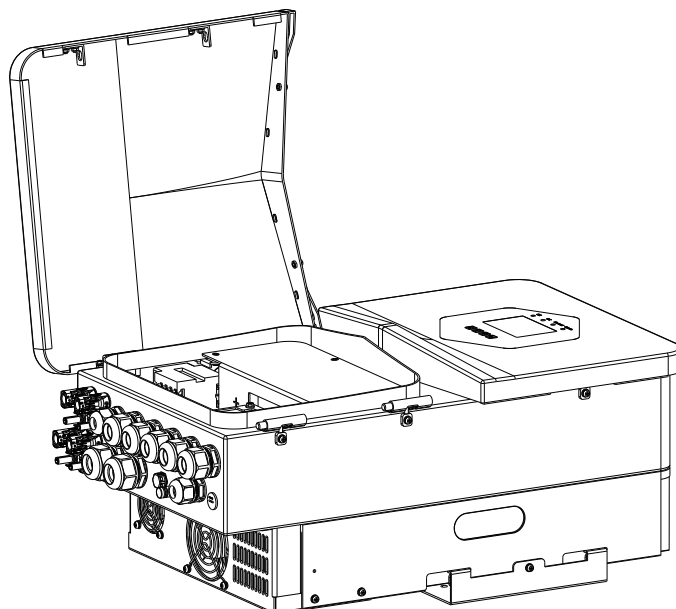

INSTALLATION GUIDELINES

- Install on a vertical wall: Choose a vertical wall with sufficient load-bearing capacity, such as concrete or another non-flammable surface. This will ensure proper stability.
- Mount at eye level: Position the inverter at eye level to allow easy access to the LCD display for continuous monitoring and configuration.
- Temperature range: Ensure the ambient temperature is between -40°C and 60°C for optimal inverter performance.
- Clearance for heat dissipation: Ensure there is adequate clearance around the inverter for heat dissipation and ease of wire management:
 - 500 mm clearance on each side
 - 500 mm above and below the unit
 - 1,000 mm in front of the unit for proper air circulation
- Indoor installation: If installing indoors, ensure the floor height is greater than 1,600 mm to allow proper airflow and clearance.

This layout ensures that the inverter operates efficiently and safely, while also protecting it from potential environmental factors that could reduce its performance or lifespan.

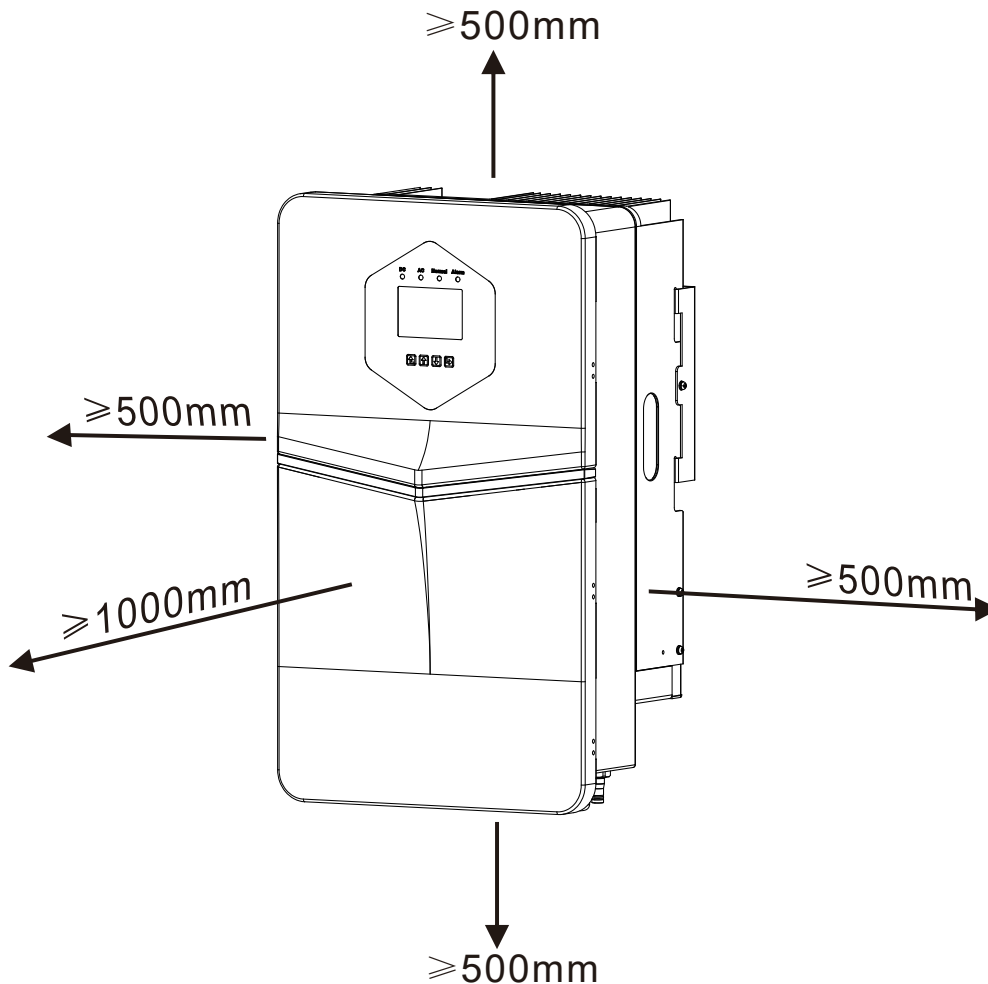

Mounting the Inverter

- Prepare the wall for mounting: Select the recommended drill bit (as shown in the image) and drill four holes into the wall to a depth of 62–70 mm.
- Fit the expansion bolts: Use an appropriate hammer to insert the expansion bolts into the drilled holes, ensuring a secure fit.
- Hang the inverter: Carefully lift and hold the inverter, aligning the hanger arms with the expansion bolts. Secure the inverter onto the wall, ensuring it is properly positioned.
- Fasten the expansion bolts: Tighten the heads of the expansion bolts to securely fix the inverter to the wall.



CAUTION

Risk of Injury (Heavy Object)

The inverter is heavy. Please ensure that the unit is handled carefully during installation, especially when mounting or removing it from the wall. Always use proper lifting techniques and, if possible, have two people assist with the mounting process to avoid injury.

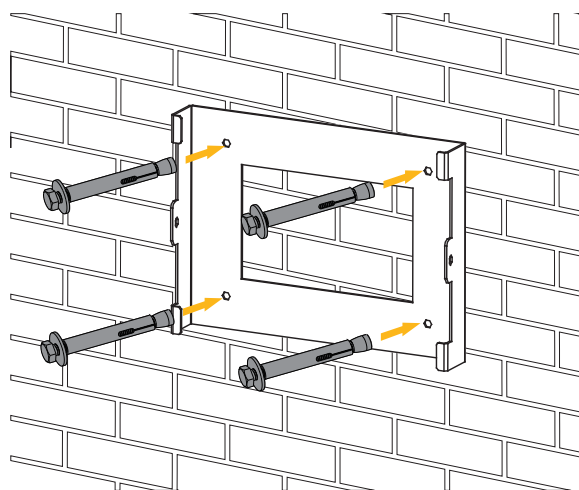

Inverter hanging plate installation

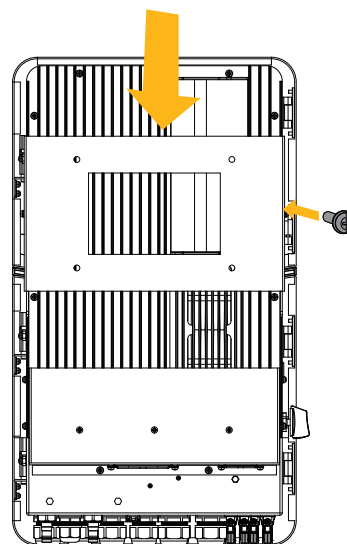

Battery Connection

For safe operation and compliance, a separate DC over-current protector or disconnect device is required between the battery and the inverter. While switching devices may not be necessary in some applications, over-current protectors are still mandatory. Refer to the typical amperage table below for the required fuse or circuit breaker size.

Model	Wire Size	Cable (mm ²)	Torque Value (max.)
3.6kW	2AWG	25	5.2N.m
5kW	1AWG	35	5.2N.m
6kW	0AWG	50	5.2N.m
7/8kW	3/0AWG	70	5.2N.m



WARNING

Qualified Personnel Required

All wiring and connections must be performed by qualified personnel. Before making the final DC connection or closing the DC breaker/disconnection device, ensure the inverter unit is wired correctly. A reverse-polarity connection to the battery can cause irreparable damage to the inverter.

Please follow the steps below to complete the battery connection:

1. Select the correct battery cable: Choose a suitable battery cable with the appropriate connector that fits securely into the battery terminals.
2. Connect the battery: Use a suitable screwdriver to loosen the bolts. Attach the battery connectors, then tighten the bolts using the screwdriver to ensure a secure connection. Tighten the bolts to a torque of 5.2 N·m in a clockwise direction.
3. Check polarity: Verify that the polarity at both the battery and inverter is correctly connected.
4. Ensure water-resistant connection: To protect against moisture, insects, and unintended access by children, ensure that the inverter connector is firmly secured. Turn it clockwise until it is fully tightened in a waterproof position.

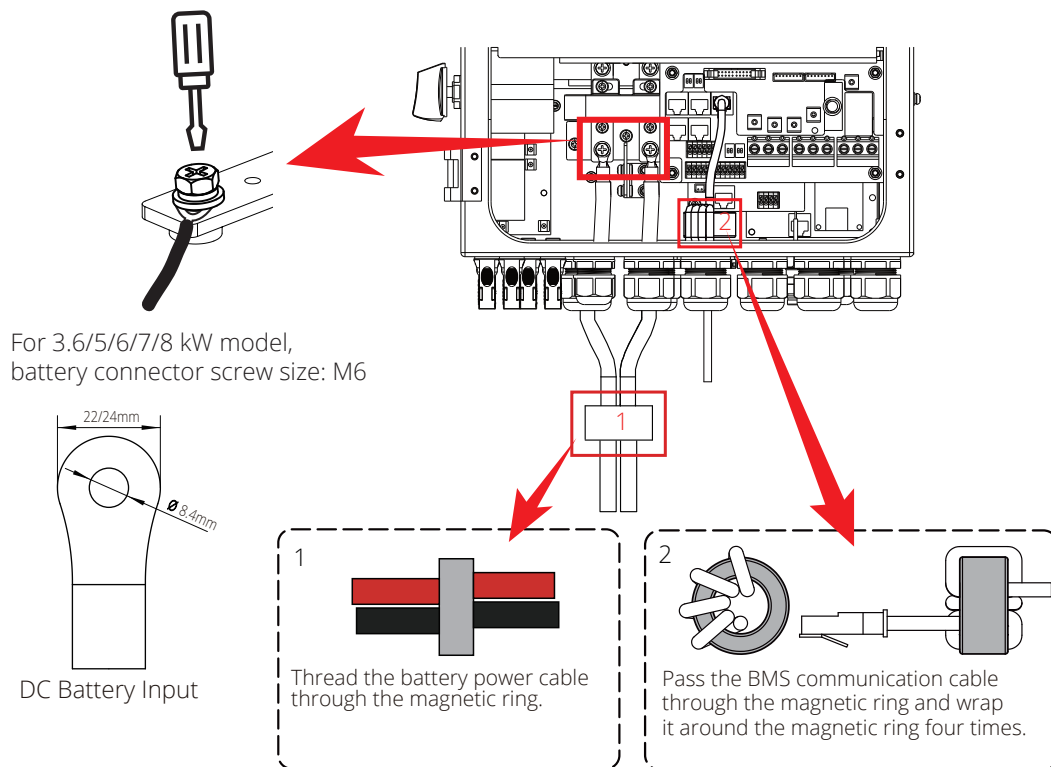

WARNING

Reverse Polarity Risk

Before making the final DC connection or closing the DC breaker/disconnect device, ensure that positive (+) is connected to positive (+) and negative (-) to negative (-). A reverse-polarity connection to the battery will cause damage to the inverter.

Recommended DC Battery Protection

DC battery protection is a crucial component of any solar energy system that includes batteries and inverters. It ensures the safe operation of the system by protecting against electrical faults such as overcurrent, short circuits, and reverse polarity.

The key components of DC battery protection typically include fuses, circuit breakers, and isolators, all of which help prevent equipment damage, electrical fires, or personal injury.

OVERCURRENT PROTECTION (FUSES & CIRCUIT BREAKERS)

- Fuses or circuit breakers are installed to protect the battery and the inverter from overcurrent situations.
- An overcurrent protector (usually a fuse or circuit breaker) prevents excessive current flow that could damage the inverter or battery. If the current exceeds a safe level, the fuse blows or the breaker trips, stopping the flow of electricity.

ISOLATOR SWITCHES

- Isolator switches allow the user to disconnect the battery from the rest of the system for maintenance, troubleshooting, or emergency situations.
- The isolator switch typically works in conjunction with the fuse or circuit breaker, ensuring that the system is properly isolated and safe for working.

VOLTAGE AND REVERSE POLARITY PROTECTION

- Voltage regulators or protection circuits are often installed to prevent damage caused by voltage spikes.
- Reverse polarity protection ensures that if the positive and negative terminals are connected incorrectly, it will not cause damage to the inverter or battery. This is critical to prevent costly repairs.

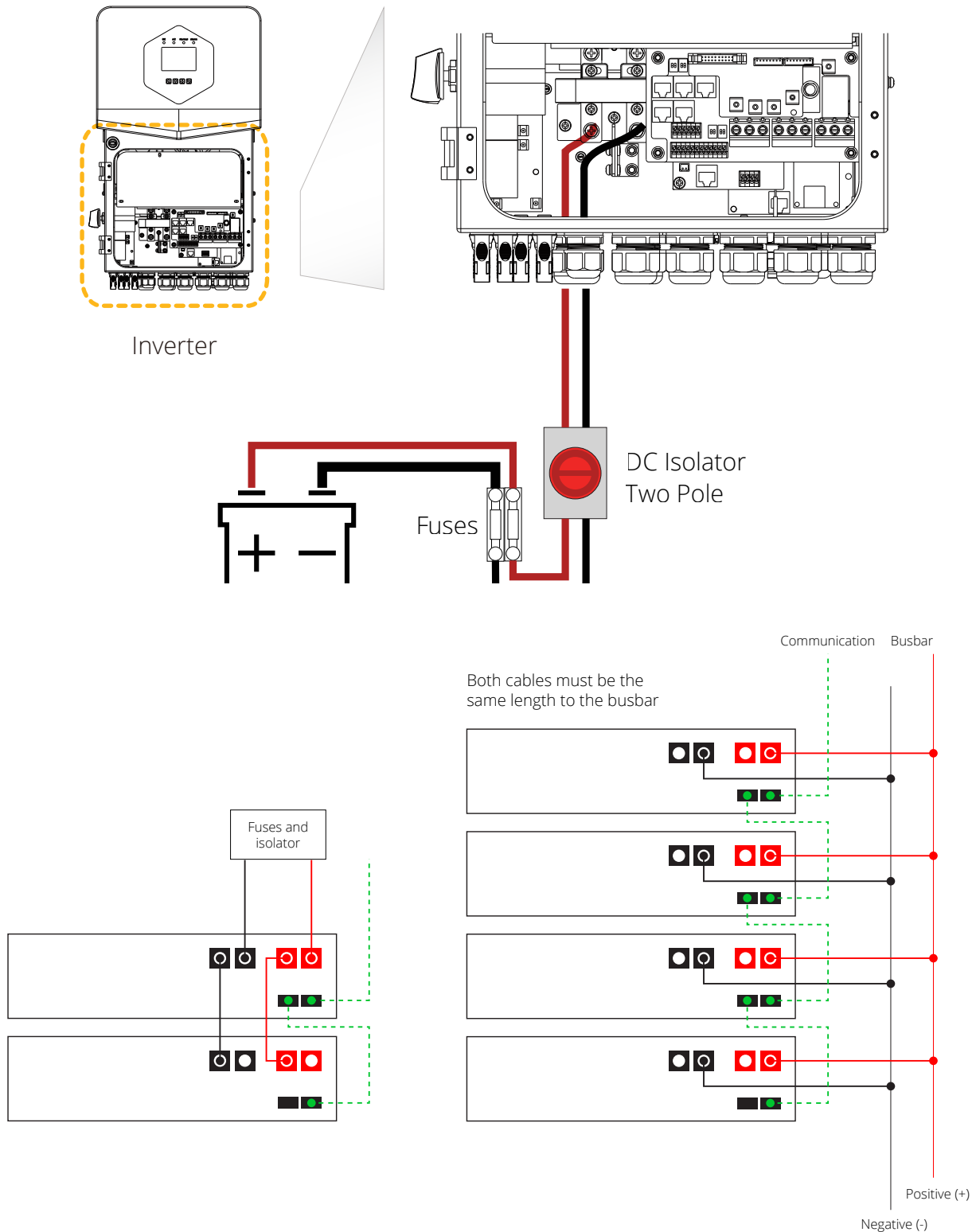

Function Port Definition

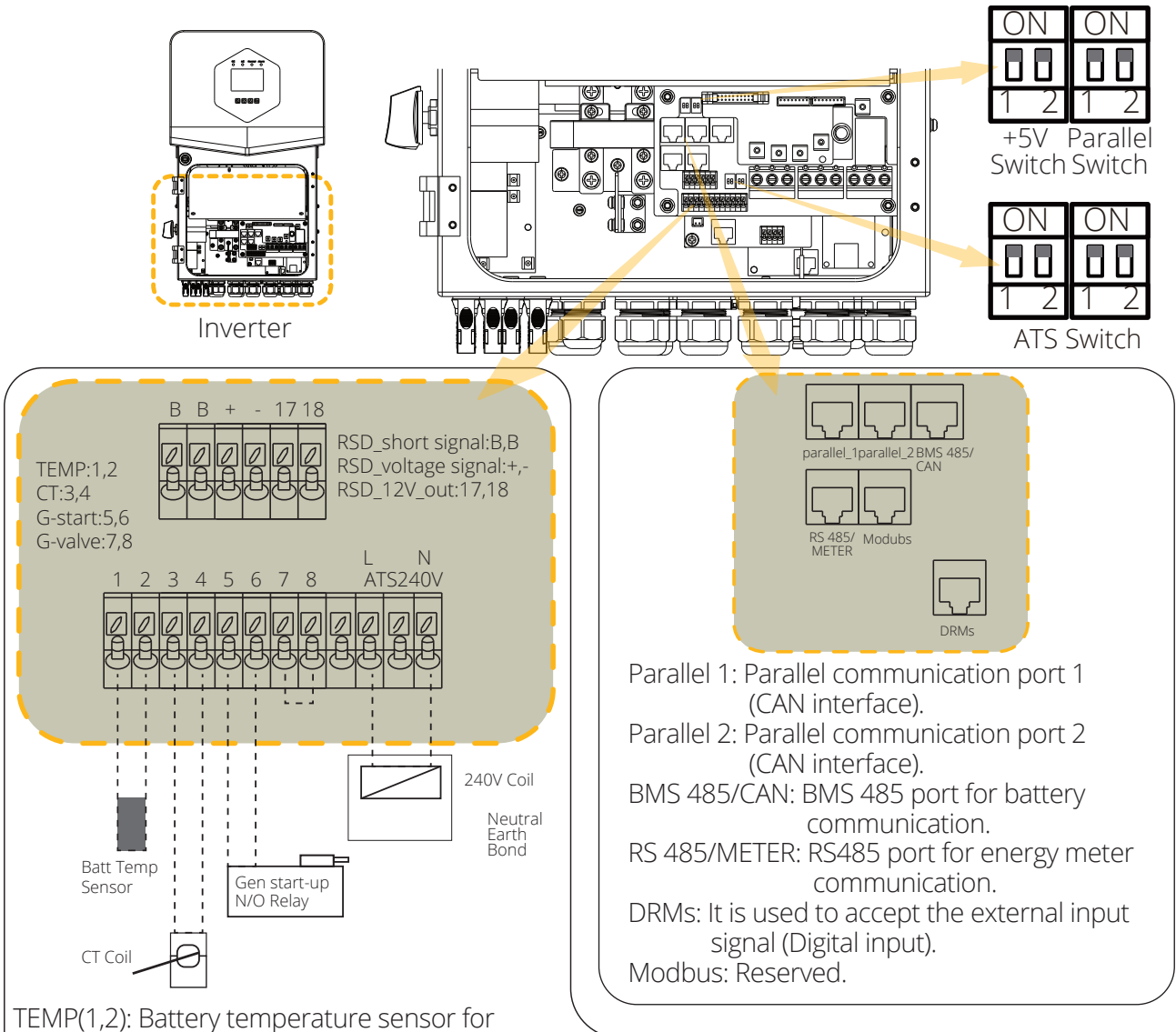

TEMP(1,2): Battery temperature sensor for lead acid battery.

CT(3,4): Current transformer for "zero export to CT" mode.

G-start/G-valve(5,6/7,8): Dry contact signal for startup the diesel generator.

When the "GEN signal" is active, the open contact (G-start/G-valve) will switch on (no voltage output). If the "Signal ISLAND MODE" is ticked, the G-valve port will be the dry contact signal for startup the diesel generator. If "Signal ISLAND MODE" is not ticked, the G-start port will be the dry contact signal for startup the diesel generator.

ATS240V: If the conditions are met, it will output 230Vac.

ATS Switch: This DIP Switch (2 set) is used to turn on/off the output voltage of ATS port. When both of them is in "ON" position, then the output voltage of ATS port will be active. When both of them is in "OFF" position, then the output voltage of ATS port will be not active.

RSD_short signal/RSD_voltage signal(B,B/+,-): When the terminal "B" & "B" is short-circuited with additional wire connection, or there's 12Vdc input at the terminal "+ & - ", then the 12Vdc of RSD+ & RSD- will disappear immediately, and the inverter will shutdown immediately.

RSD_12V_out(17,18): When battery is connected and the inverter is in "ON" status, it will provide 12Vdc.

Paralle Switch: Parallel communication resistor. If the number of inverters in the parallel system is less than or equal to 6, all inverter's DIP switch (1&2) need be ON position. If the number of inverters in parallel system exceeds 6, the main 6pcs inverter's DIP switch needs to be ON position. And the other inverter DIP switch (1&2) needs to be OFF position.

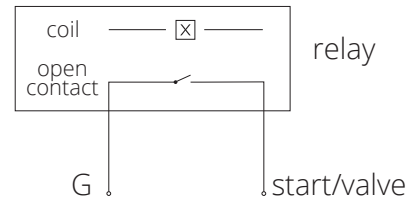

G-start/G-valve

(diesel generator startup signal)

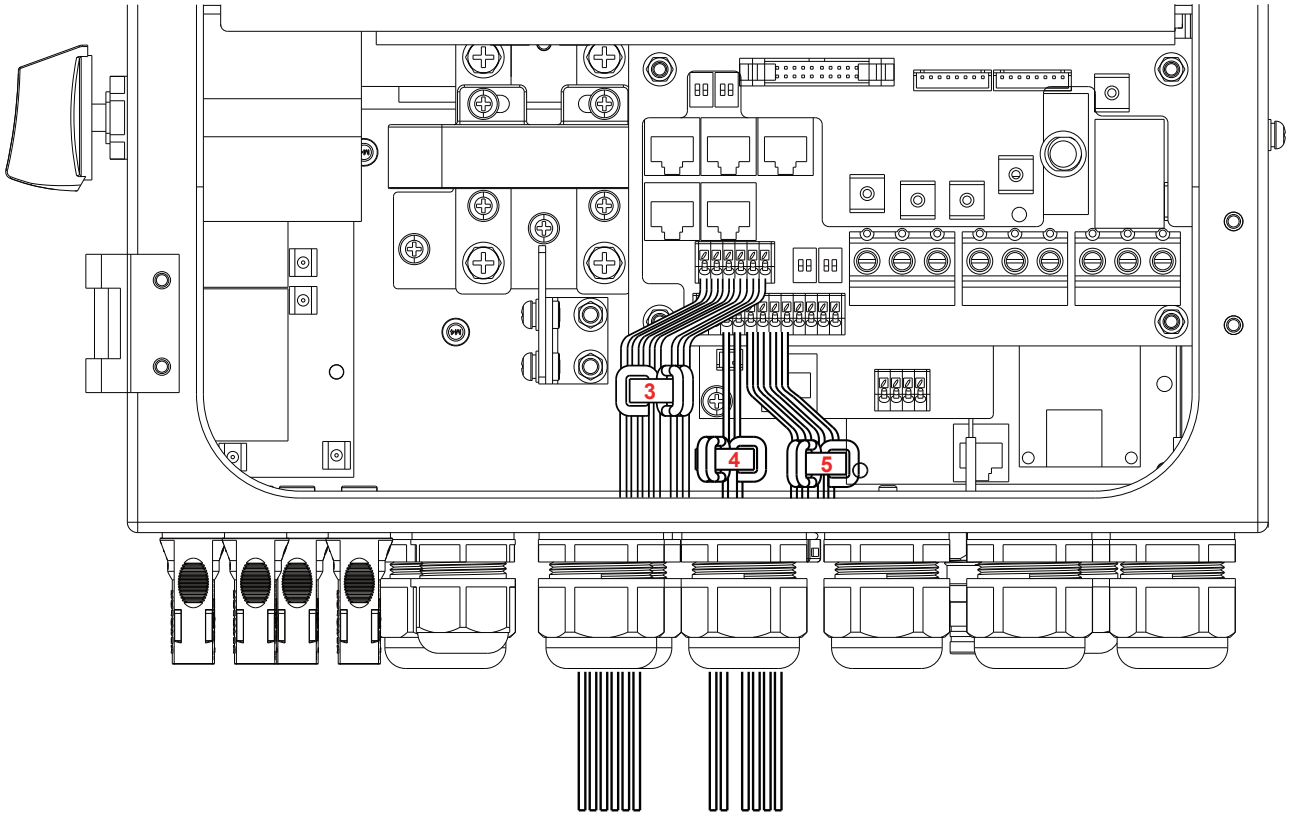

No.	Function Port	Installations Instructions
3	RSD_short signal (B,B) RSD_voltage signal (+,-) RSD_12V_out (17,18)	Wrap the wires three laps around the magnetic ring, then thread the end of wires through the magnetic ring.
4	CT(3,4)	Wrap the wires three laps around the magnetic ring, then thread the end of wires through the magnetic ring.
5	G-start (5,6) 5 G-valve (7,8)	Wrap the wires three laps around the magnetic ring, then thread the end of wires through the magnetic ring.

Lead-Acid Battery Temperature Sensor

Without a remote temperature sensor, lead-acid batteries may undercharge or overcharge depending on the ambient temperature of the installation environment. This may result in a fire hazard.

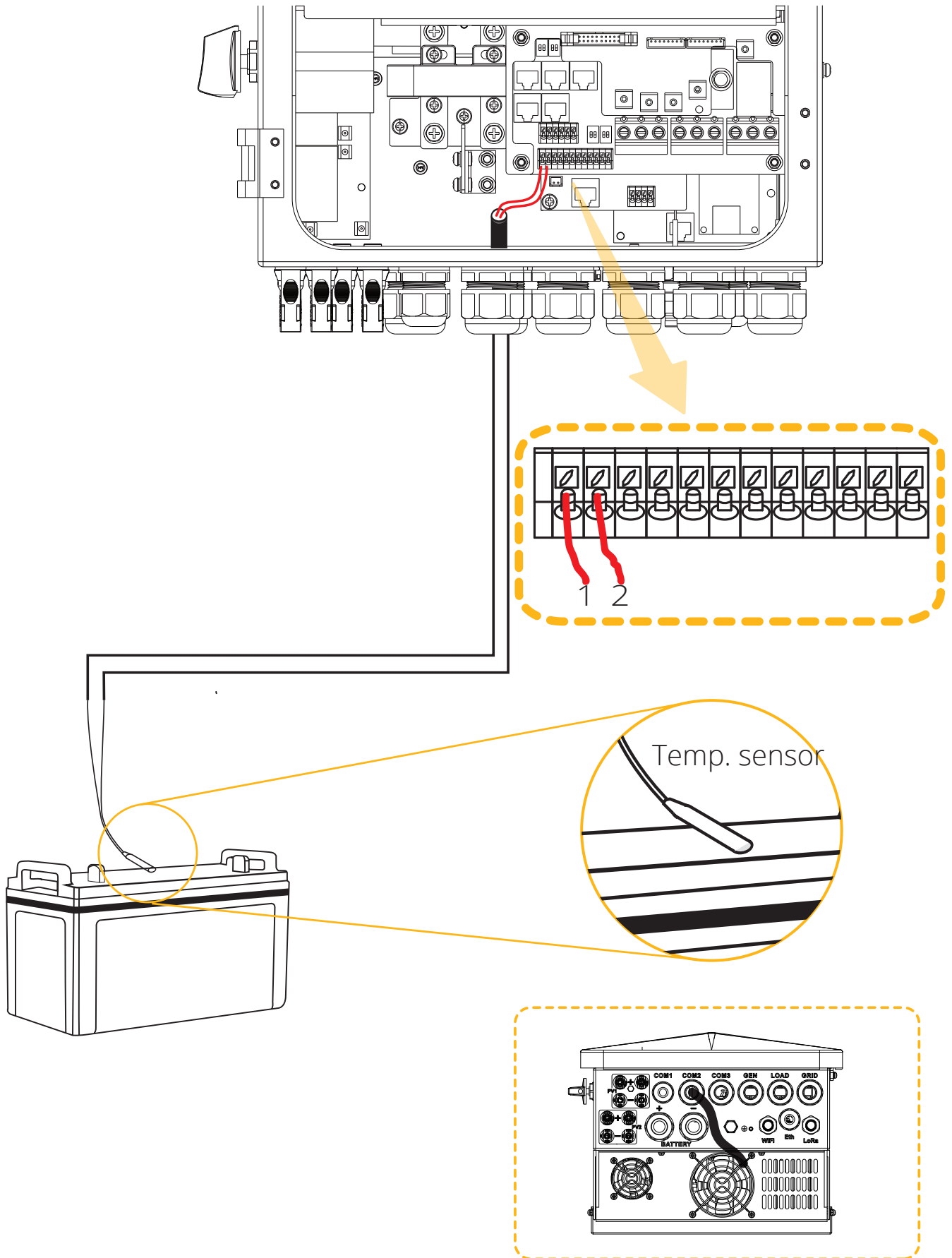

Grid, Load, and Generator Connections

Before connecting the inverter, ensure the installation of dedicated AC breakers on the Grid, Load, and GEN/AUX connections. These breakers ensure safe isolation during maintenance, protect against overcurrent, and enhance system safety.

The inverter system includes three terminal blocks, labelled "Grid", "Load", and "GEN", which must be correctly identified and connected to their respective input and output terminals.

For the 3.6 / 5 / 6 kW model, a 40 A AC breaker is recommended for the grid connection. For the 7 / 8 kW model, is recommended a 50 A AC breaker for the grid connection. Breaker sizing for Load and GEN connections should be selected based on the connected load and generator specifications. For the 3.6 / 5 / 6 kW model 40 A AC breaker is recommender for backup load. For the 7 / 8 kW model, is recommended a 50 A AC breaker for backup load.

GEN/AUX, GRID, AND LOAD CONNECTIONS

1. GEN/AUX – Generator Connection: The GEN/AUX terminal connects to a generator or auxiliary power source. It provides an input connection to the inverter, allowing it to receive power from the generator during periods when solar energy is insufficient, ensuring a continued power supply to the system.

Explanation: The inverter can work in parallel with a generator (e.g., diesel, wind, or hybrid systems) to provide power when the solar system or battery is insufficient. It ensures that the inverter can always keep essential loads powered, regardless of available solar power.

2. GRID – Grid Connection: The GRID terminal operates similarly to a conventional grid-tied inverter. It functions as both an input and an output connection:

- Input: The inverter receives grid power when solar generation is insufficient or when battery levels are low.
- Output: The inverter can supply excess energy back to the grid or provide power to non-essential loads when required.

Explanation: In grid-connected systems, the GRID terminal facilitates power flow both from and to the grid. When there is excess solar power, it can be fed back to the grid, while during cloudy days or at night, the inverter will draw power from the grid to meet energy demand.

3. LOAD – Essential Load Connection: The LOAD terminal is dedicated to connecting essential loads within your system. These typically include critical systems such as:

- Lighting
- Security systems
- Communication systems (e.g., internet or telecommunication devices)

This ensures that these essential loads receive power directly from the inverter, even during grid outages or when other non-essential loads are disconnected.

Explanation: By isolating non-essential loads and prioritising essential ones, the system ensures that critical appliances or systems remain operational, even in an off-grid scenario.



WARNING

- During final installation, ensure that a breaker certified according to IEC 60947-1 and IEC 60947-2 is installed with the equipment.
- All wiring must be carried out by qualified personnel to ensure system safety and proper operation.
- Use appropriate cables for the AC input connection as specified below.
- To minimise the risk of injury and ensure safe operation, always use the recommended cables.

Grid connection and backup load connection (copper wires)

Model	Wire Size	Cable	Torque Value (Max.)
3.6 kW / 5 / 6 kW	8 AWG	6 mm ²	1.2 N.m
7 / 8 kW	6 AWG	10 mm ²	1.2 N.m

*If your system includes a bypass supply or auxiliary earth, use the same cable and torque specifications.

INSTALLATION PROCEDURE

Follow the steps below to complete the AC input and output connections. This procedure must be carried out by qualified personnel.

1. Isolate power sources: Before connecting the Grid, Load, and Generator terminals, ensure that the AC breaker or disconnecter is switched off to prevent electrical hazards.
2. Prepare the wires:
 - Strip 10 mm of insulation from each wire end.
 - Loosen the terminal screws and ensure the terminals are ready to receive the wires.
3. Pass through magnetic ring: Thread each AC wire through the magnetic ring as shown in the installation diagram. This step is required for EMC (electromagnetic compatibility) compliance.

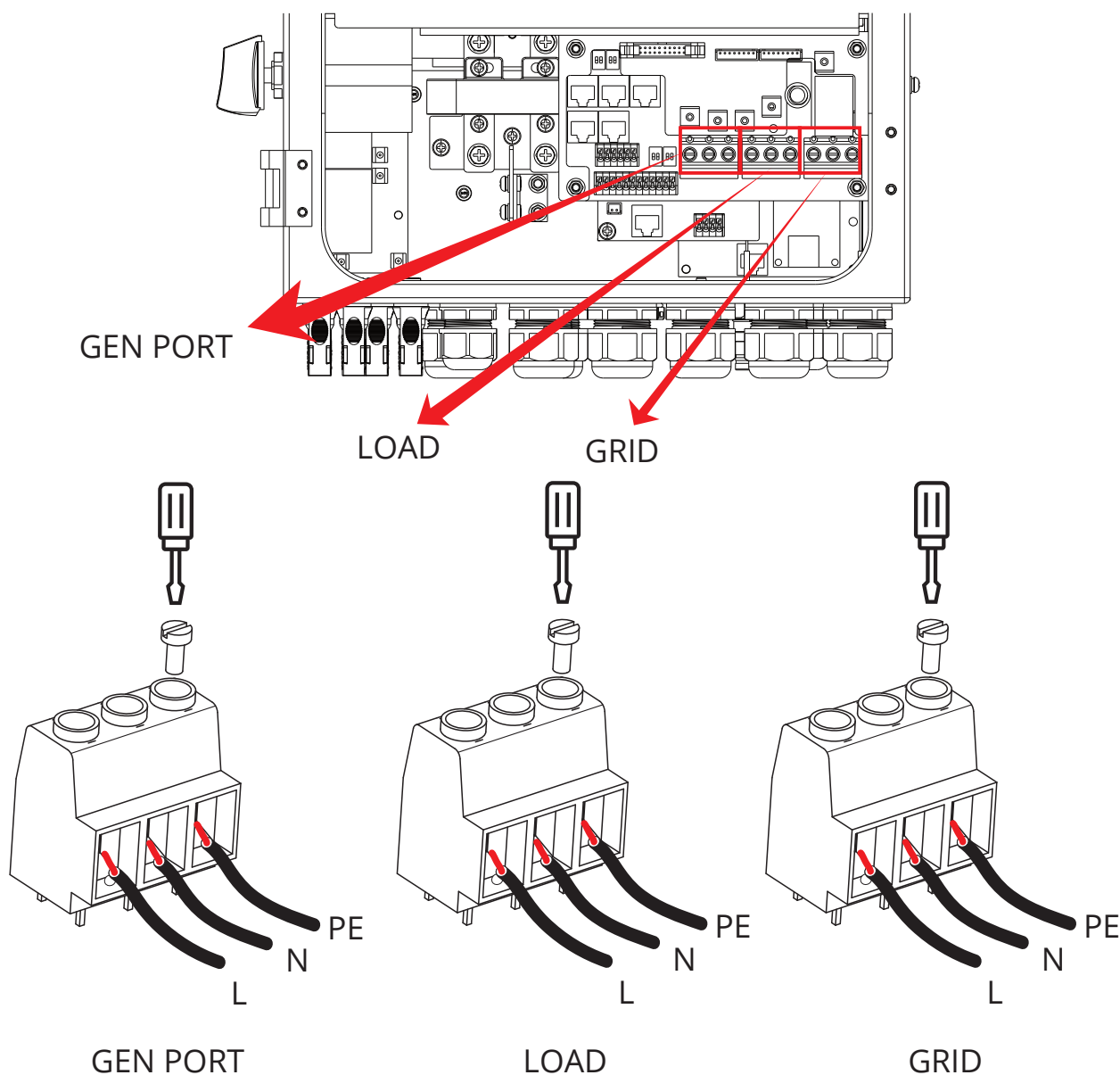

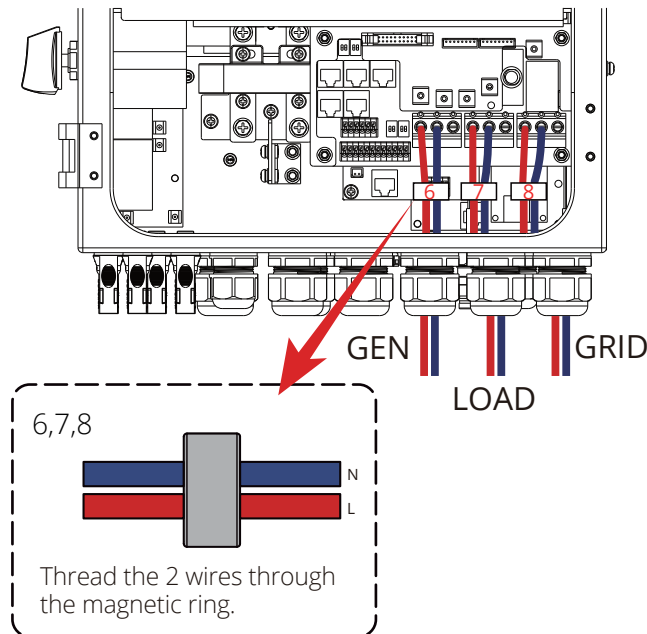

4. Connect to terminal block:
 - Insert the wires into the terminal block according to the indicated polarity (L – Live, N – Neutral, PE – Protective Earth).
 - Tighten the terminal screws securely to ensure firm and safe connections. Verify that all wires are correctly and securely fastened.
5. Connect the AC output:
 - Insert the AC output wires into the appropriate terminals, again observing the correct polarity.
 - Connect the Neutral (N) and Earth (PE) wires to their corresponding terminals.



NOTICE

Ensure all AC terminals are securely connected. Loose terminals may cause overheating, arcing, or system faults.

APPLIANCE RESTART WARNING

- Check with the appliance manufacturer to confirm whether a built-in time-delay function is included.
- If no such function is present, the inverter may enter overload protection mode and disconnect the output to protect the appliance.
- However, sudden reconnection without delay can still result in permanent damage to sensitive equipment like air conditioners.



CAUTION

Compressor-based appliances, such as air conditioners, require a restart delay of 2–3 minutes to allow refrigerant pressure to stabilise.

If power is interrupted and restored too quickly, this may damage the appliance's internal components.

Recommendations:

- Always follow proper torque values for secure terminal tightening.
- Ensure correct wire routing through the magnetic ring for compliance.
- Use only recommended cable sizes as per model specification.
- Do not skip the restart delay check for compressor-based loads.

Recommended AC Surge Protector

An AC surge protector is highly recommended for every inverter installation. It protects the inverter, battery system, and connected loads from transient overvoltages caused by lightning strikes, grid switching events, or other electrical disturbances.

The AC surge protector absorbs high-voltage surges and diverts excess energy safely to earth, preventing damage to the system's internal components.

Key Benefits:

- Prevents damage to sensitive inverter electronics.
- Increases the lifespan of the inverter and other connected devices.
- Ensures system reliability, especially in areas with unstable grid voltage or frequent lightning activity.
- Required for compliance with local and international electrical installation standards.

INSTALLATION GUIDELINES

1. Install between the grid and inverter:

- The surge protection device should be installed between the AC grid supply and the inverter's AC input terminal.
- It must be connected as close as possible to the point of entry of the AC supply to ensure maximum protection.

2. Connect to earth:

- Ensure the surge protector is properly earthed. A poor or missing earth connection will render the device ineffective and unsafe.
- The earth connection must be stable and reliable to protect the entire system effectively.

3. Enclosure requirements:

- The AC surge protection system should be installed in a weatherproof IP-rated enclosure if mounted outdoors.
- The diagram shows an example of a surge protection box with an integrated rotary isolator, MCBs (Miniature Circuit Breaker), and SPD (Surge Protection Device).



NOTICE

Surge protection devices cannot replace the need for proper grounding. Always verify that the inverter, SPD, and distribution board are connected to a properly tested earth point to ensure complete system safety.

PV Connection

Before connecting the PV modules to the inverter, a separate DC circuit breaker must be installed between the inverter and the solar array. This is critical for ensuring system safety and efficient operation. Always use the correct cable size as specified below:

Model	Wire Size	Cable
3.6/5/6/7/8 kW	12 AWG	2.5 mm ²



WARNING

Do not connect any PV modules that may have potential leakage to the inverter. Leakage could cause malfunction or even damage to the inverter. When connecting the PV modules, ensure the positive (+) and negative (-) terminals are correctly aligned and not grounded.

It is recommended to use a PV junction box with surge protection to prevent damage from lightning strikes or other electrical disturbances affecting the solar modules.

PV Module Selection

When selecting PV modules, please consider the following parameters to ensure proper operation and compliance with system requirements:

1. Open circuit voltage (Voc): The Voc must not exceed the maximum input voltage rating of the inverter to prevent overvoltage conditions and ensure the system operates safely.
2. Voc should be higher than the inverter's minimum start-up voltage: The Voc should exceed the inverter's minimum start-up voltage to ensure that the inverter can begin operating correctly under all conditions.
3. Class II certification: The PV modules connected to this inverter must be Class II rated and certified according to IEC 61730. This certification ensures the modules meet international safety standards and are suitable for use with the inverter.
4. Short-circuit current (Isc): The short-circuit current (Isc) of the PV array must not exceed the maximum input current rating of the inverter. Exceeding this value could cause damage to the inverter and pose a safety risk.
5. Ensure proper system compatibility:
 - The modules must be selected in accordance with the inverter's maximum voltage and current ratings.
 - Always verify that the system's design allows for safe operation under various conditions, including shading and environmental factors that may affect performance.

Model	3.6 kW / 5 kW / 6 kW	7 kW / 8 kW
PV Input Voltage	370 V (125 V ~ 500 V)	
PV Array MPPT Voltage Range	150 V - 425 V	
No. of MPP Trackers	2	
No. of Strings per MPP Tracker	1+1	2+2

PV Module Wiring

1. Switch off the grid supply main switch (AC): Ensure the AC grid connection is turned off by switching the Grid Supply Main Switch to the OFF position. This will isolate the inverter from the grid and prevent any electrical hazards during installation.
2. Turn off the DC isolator: Switch the DC isolator to the OFF position to disconnect the solar array from the inverter. This step is critical for isolating the DC side of the system and preventing any accidental electrical contact during the wiring process.
3. Assemble the DC input connector: Assemble the DC input connector (according to the manufacturer's guidelines) and securely connect it to the inverter's DC input terminals. Ensure the connector is firmly seated and locked in place to avoid loose connections.



WARNING

Never connect the positive (+) and negative (-) terminals of the PV array to the ground. Doing so can cause severe damage to the inverter's internal components.

Before connecting, double-check the polarity of the PV array's output voltage to ensure it matches the "DC+" and "DC-" markings on the inverter's terminals.



NOTICE

Always use approved DC cables that comply with the required electrical standards. This ensures the system operates safely and efficiently, protecting both the inverter and other connected equipment from potential electrical faults.

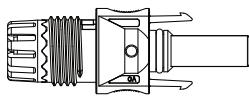

DC+ Male Connector

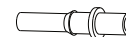
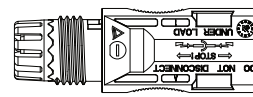

DC- Female Connector

The correct steps in assembling the DC connector are explained below:

1. Strip 7mm of the plastic coating off the DC wire and disassemble the connector cap nut.

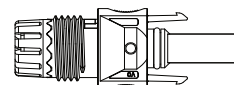
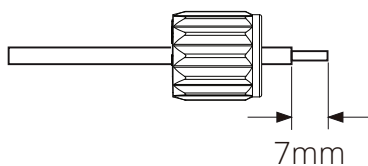
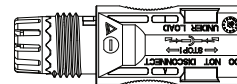
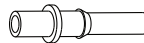
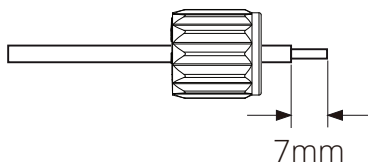

Disassemble the connector cap nut

2. Crimp metal terminals with crimping pliers.

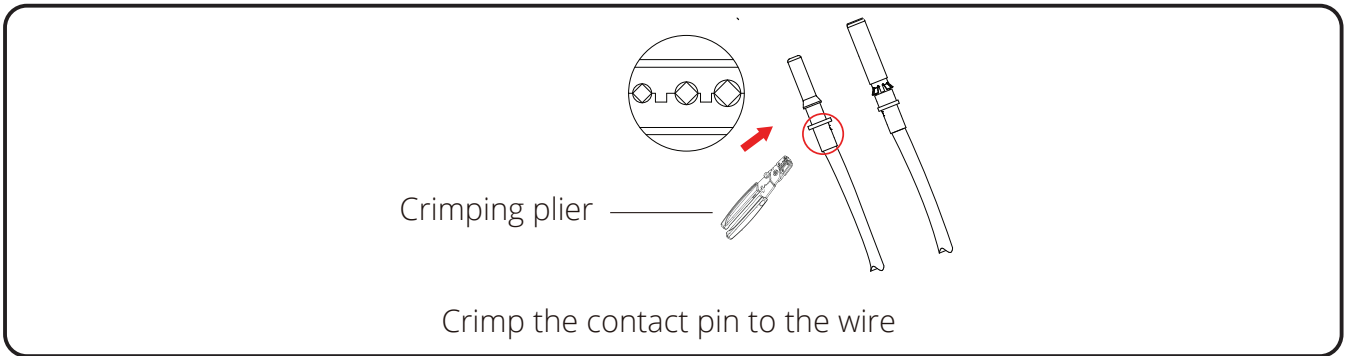

3. Insert the contact pin into the connector housing until it locks into place. Then screw the cap nut onto the connector housing. Torque to 2.5-3 N.m.

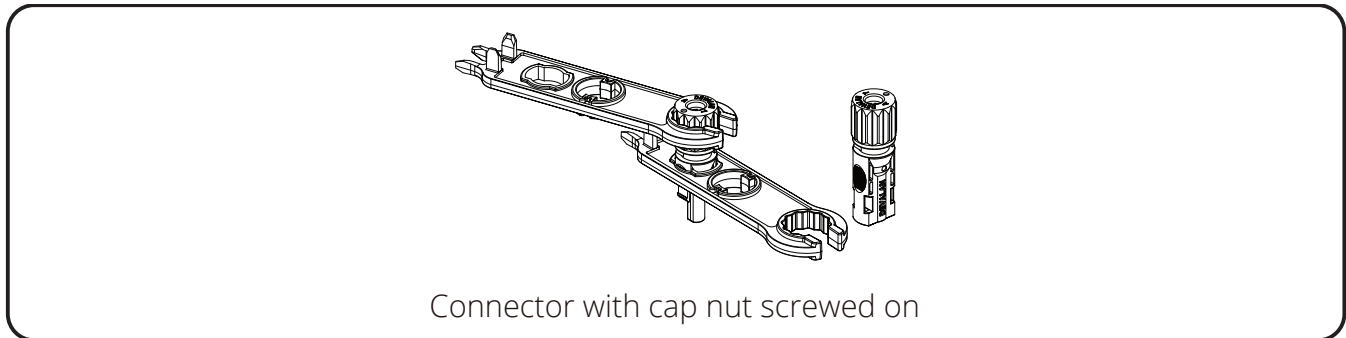

4. Finally, insert the DC connector into the positive and negative input of the inverter.

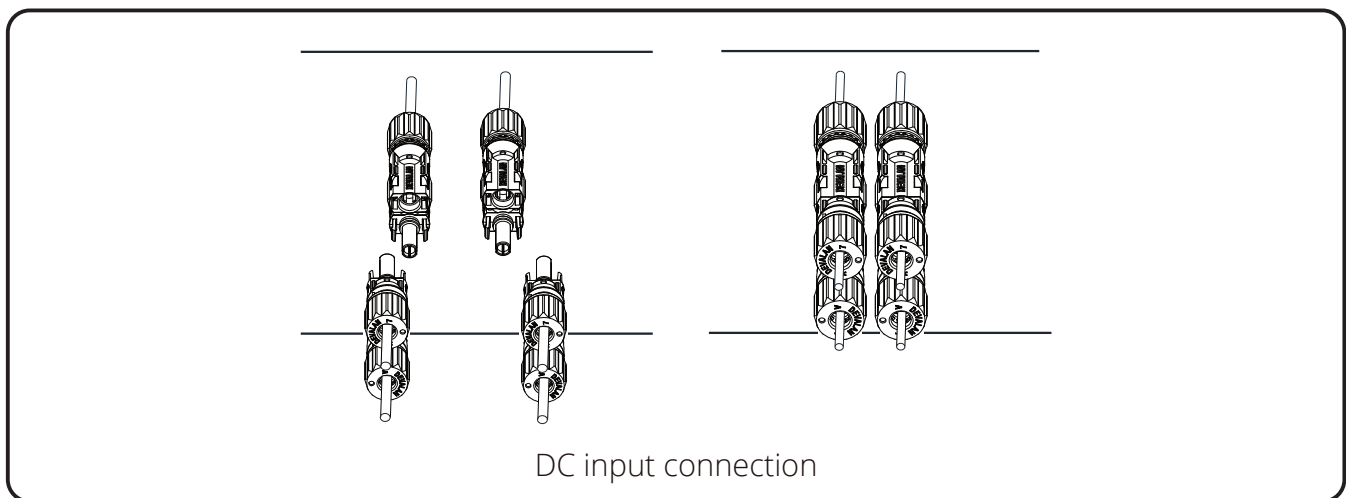

WARNING

Risk of Electric Shock

Solar panels generate voltage as soon as they are exposed to light. A series-connected PV array can produce dangerously high voltage, even under cloudy conditions.

- Before handling any DC wiring, cover the solar panels with an opaque material to prevent power generation.
- Ensure the DC switch is in the OFF position before beginning work.
- Failure to do so may result in life-threatening electric shock.

PV Protection

The Sunsynk PV Combiner Box is an integral component of the solar power system, providing both protection and simplification for connecting multiple solar panel strings to the inverter. The PV Combiner Box combines the outputs of multiple PV strings, ensuring optimal operation and safeguarding the system against overvoltage and overcurrent conditions.

IMPORTANCE OF PV PROTECTION

1. Surge protection: The Surge Protection Device (SPD) in the PV Combiner Box protects the system from voltage spikes caused by lightning or grid surges by safely diverting excess voltage to the ground.
2. Overcurrent protection: Fuses in the combiner box protect each solar string from short circuits or overloads, ensuring the system operates safely.
3. System safety: DC disconnect switches allow safe isolation of the strings and inverter for maintenance or in case of faults, reducing the risk of electrical hazards.
4. Easy installation: The Sunsynk PV Combiner Box is pre-configured for easy installation. It simplifies the process, ensuring a reliable and quick setup.

PV COMBINER BOX INSTALLATION GUIDELINES

1. Choose the correct location:
 - Install the PV Combiner Box near the solar array to minimise voltage drop.
 - Place it in a ventilated, weatherproof area (IP-rated if outdoors) for easy maintenance.
2. Ensure proper grounding: The PV Combiner Box must be properly earthed to protect against electrical faults and lightning.
3. Connect the PV strings:
 - Connect the positive and negative terminals of each solar string to the appropriate inputs in the PV Combiner Box using correctly rated cables.
4. DC disconnect: Use the DC disconnect switches to isolate the system when needed, especially for maintenance.
5. Install surge protection: Ensure the surge protection devices (SPDs) are installed and connected to the grounding system.
6. Follow manufacturer's specifications: Always refer to the manufacturer's installation manual to ensure correct installation and compliance with local electrical codes.



NOTICE

The Sunsynk PV Combiner Box is pre-configured and ready for installation. No additional assembly is required by the installer, making the installation process quicker and safer.

Ensure that qualified personnel perform the installation and that all electrical connections are made according to local regulations.

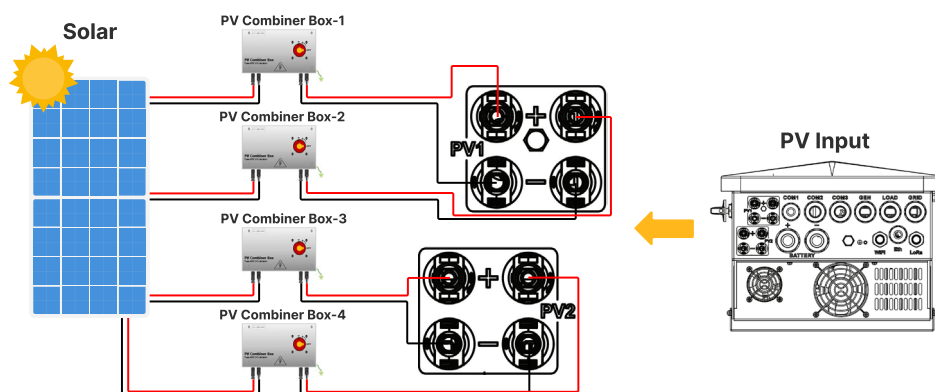

CT Coil Connection

The CT (Current Transformer) coil is a crucial component of the Sunsynk Parity inverter, responsible for enabling the Zero Export feature. This feature prevents the inverter from feeding excess power back to the grid by monitoring the flow of power.

INSTALLATION STEPS

1. Fit the CT coil:
 - Position the CT coil (sensor) around the live cable of the main fuse that supplies power to the building.
 - Ensure that the coil is installed correctly to measure the current flow accurately.
2. Run the cable to the inverter:
 - Extend the cable from the CT coil to the inverter. The cable length can be extended beyond 10 meters if you're using an external meter.
 - Always refer to the meter's manual to confirm the maximum allowed cable length for your installation.
3. Connect to the inverter: Connect the other end of the CT coil cable to the inverter's CT coil terminals, which are clearly marked as "CT coil".

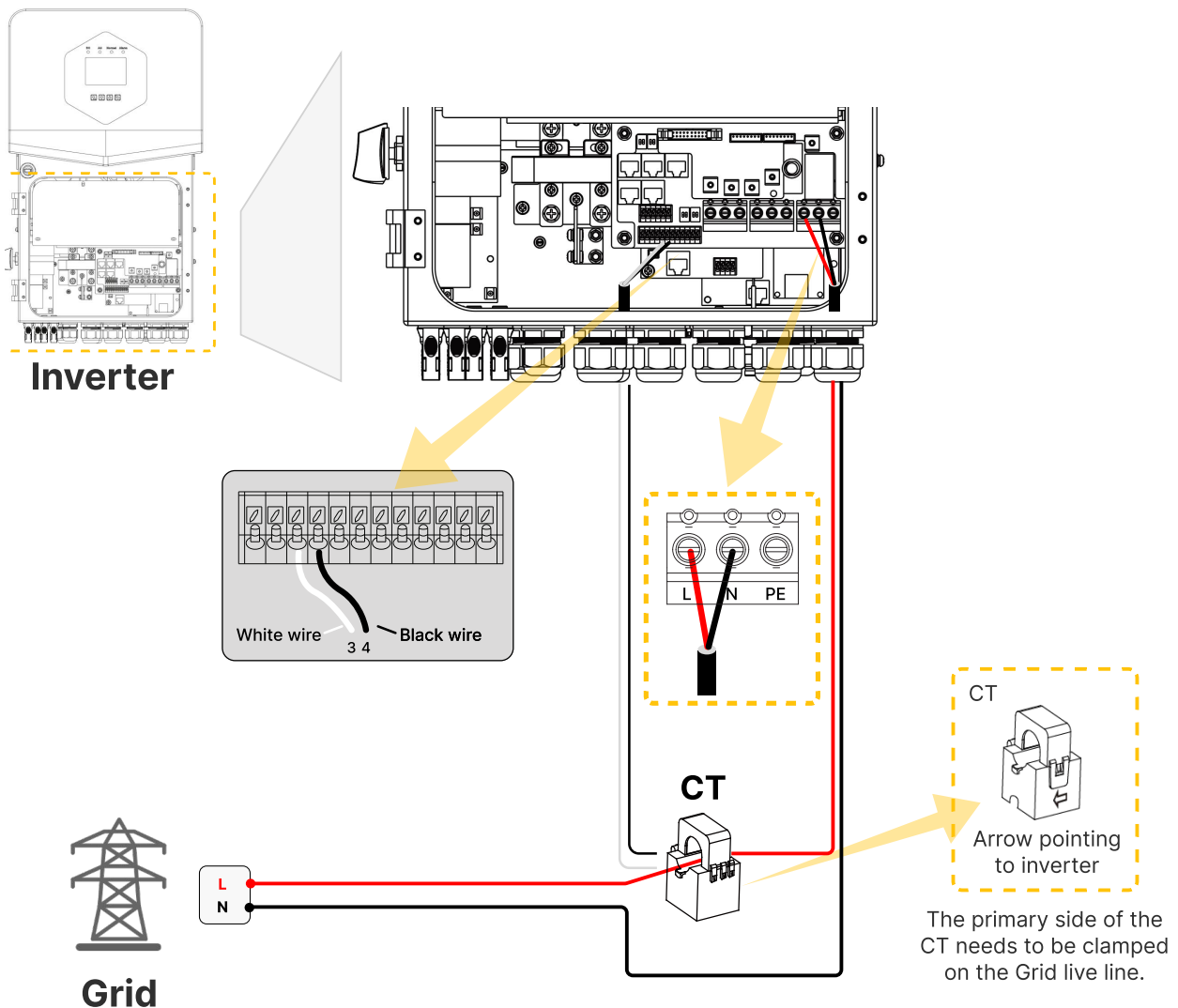

WARNING

If the load power reading on the LCD display is incorrect, reverse the CT arrow to correct the reading.

Eastron Meter

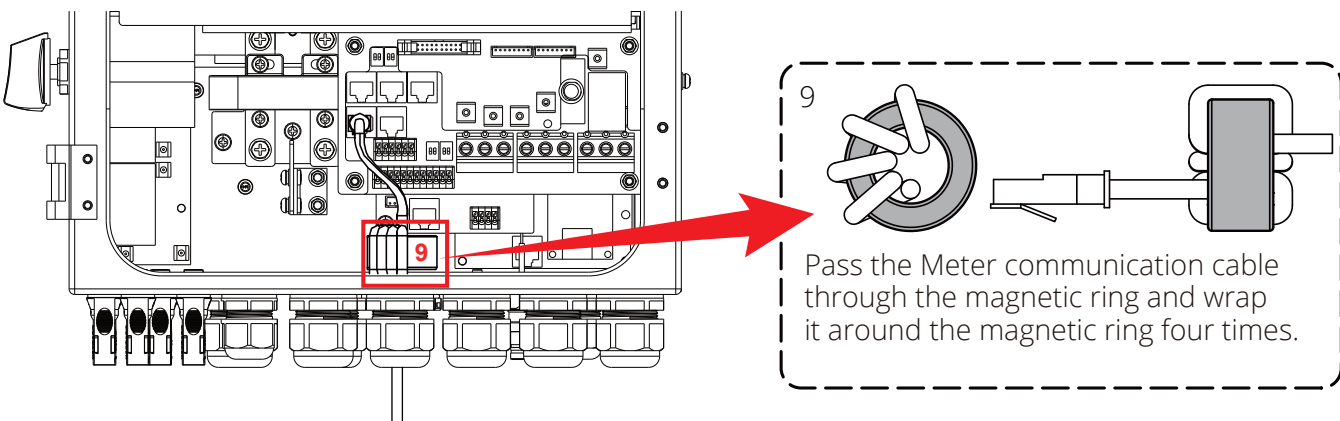
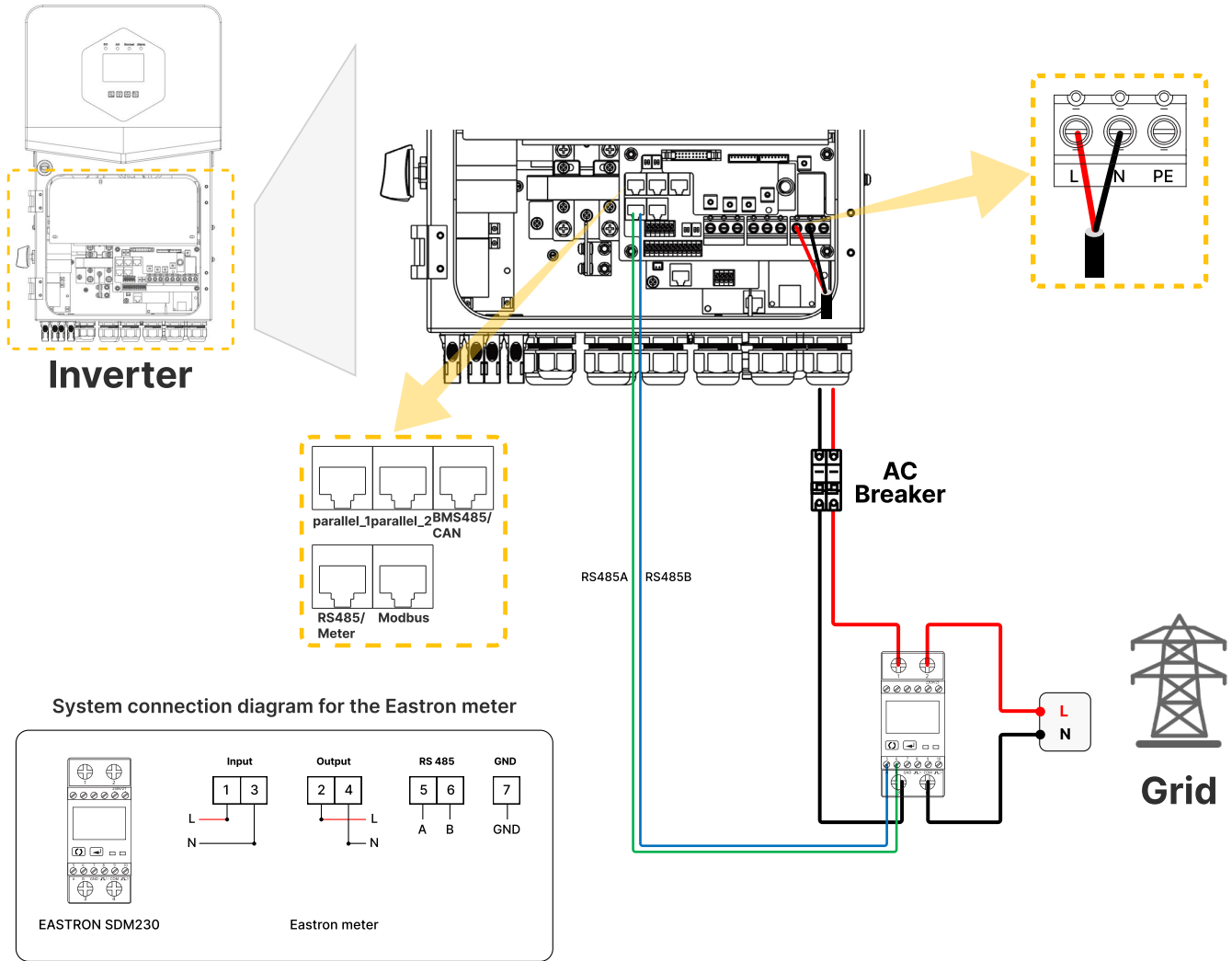

Earth Connection (MANDATORY)

To ensure electrical safety and compliance, an Earth Cable must be connected to the earth plate on the grid side of the inverter. This connection protects users and equipment in the event of a fault or insulation failure by providing a safe path for fault current. Please see below the purposes of correct earthing:

- Prevents electric shock during fault conditions.
- Ensures proper functioning of RCDs (Residual Current Devices).
- Protects the inverter and loads from surge damage and leakage current.
- Reduces the risk of fire due to electrical faults.

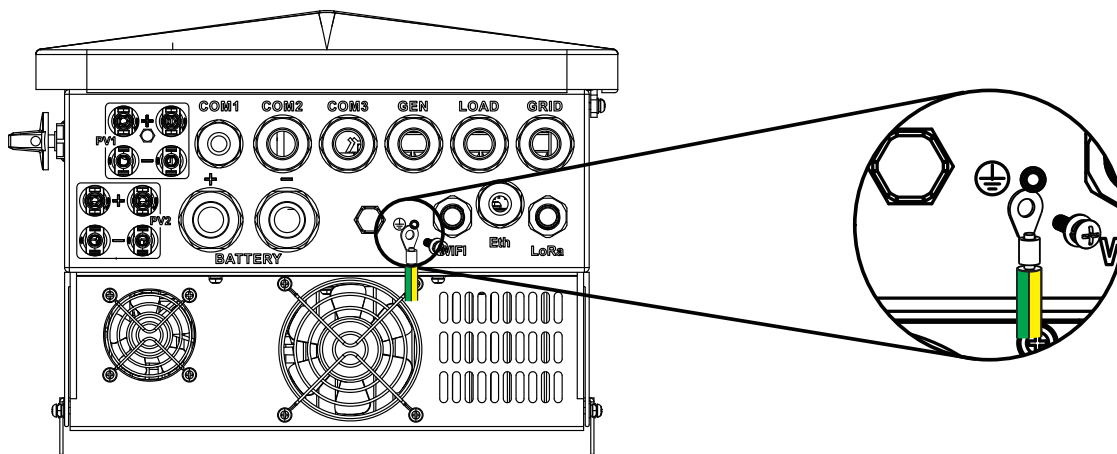

The inverter includes a dedicated earth terminal on its chassis. Use the values below when selecting and installing earth cables:

Model	Wire Size	Cable	Torque Value (max)
3.6 / 5 / 6 kW	8 AWG	6 mm ²	1.2 Nm
7 / 8 kW	6 AWG	10 mm ²	1.2 Nm

*If your system includes a bypass supply or auxiliary earth, use the same cable and torque specifications.



WARNING

Ensure the earth cable is securely tightened using the correct torque value to maintain reliable grounding.

NEUTRAL-EARTH BONDING AND SYSTEM TYPES

- All neutrals can be linked together to maintain the neutral-earth bond.
- In off-grid or backup mode, a Neutral-Earth bond is required and is handled automatically by the inverter's internal relay.
- In grid-tied mode, this bond must be disconnected, or it can cause RCD faults. The inverter's auto-bond relay ensures this transition is done safely.



CAUTION

If a permanent earth bond is used between neutral and earth in a hybrid system, it may cause unwanted RCD tripping unless properly managed.



NOTICE - For South Africa

- It is recommended to install a permanent PE/N bond on the Load Output terminal.
- The AC supply to the grid port should be taken upstream of the main RCD to avoid nuisance tripping.
- This bond must be clearly marked (e.g. "Permanent PE/N Bond") and installed in accordance with local regulations.
- Always consult your local authority or electrical inspector when installing in regions with specific bonding rules.

LEAKAGE CURRENT DETECTION AND RDC USE

The inverter is equipped with built-in leakage current detection. You may connect a Type A RCD to the inverter's AC output for additional protection.



WARNING

If using an external RCD, its rated residual operating current must be ≥ 300 mA. Lower-rated RCDs may trip unnecessarily due to inverter switching behaviour.

Wiring System for Inverter

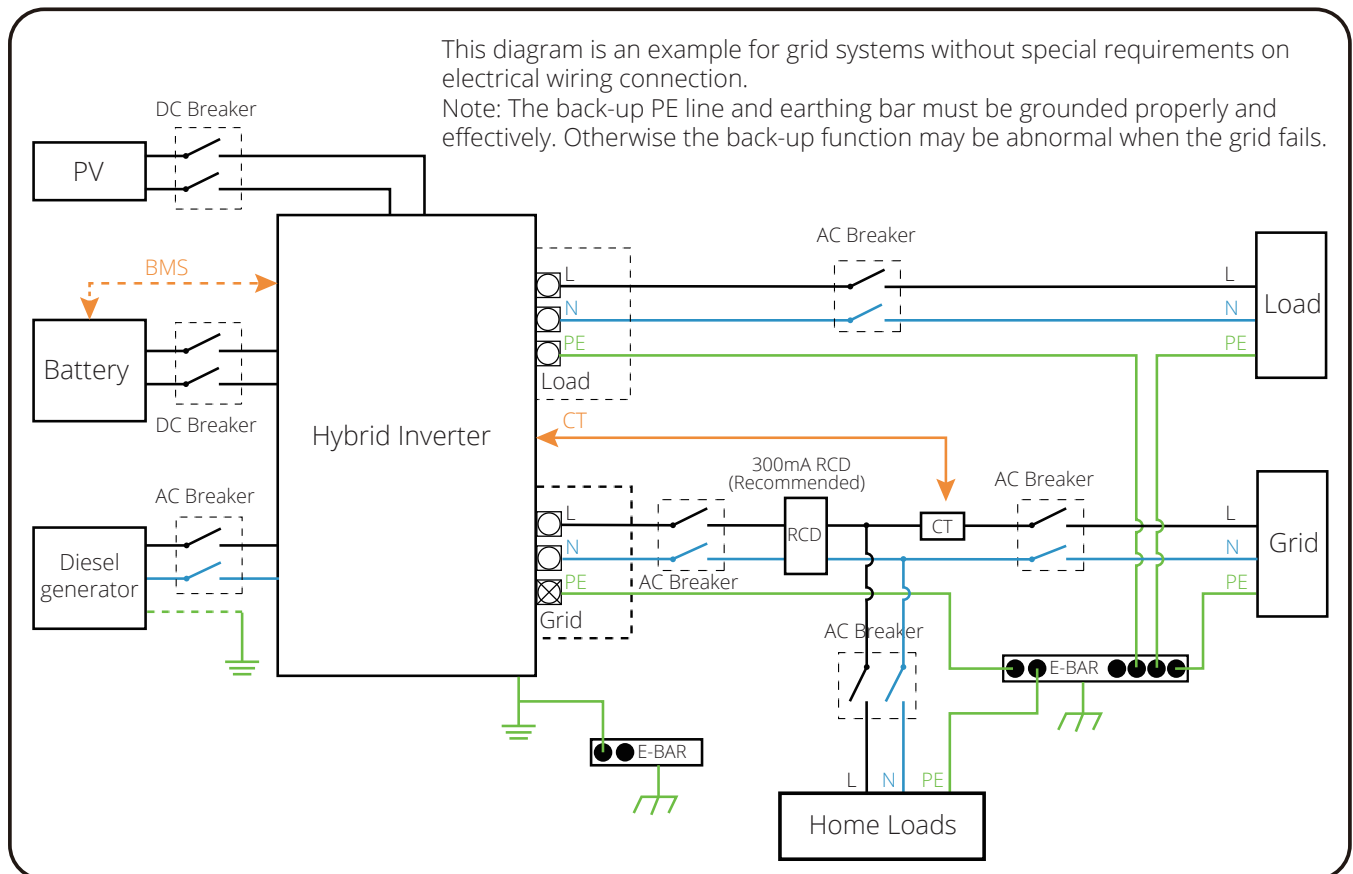

This diagram is an example for application that Neutral connects together with PE in distribution box.
Such as: Australia, New Zealand, etc. (Please follow local wiring regulations!)

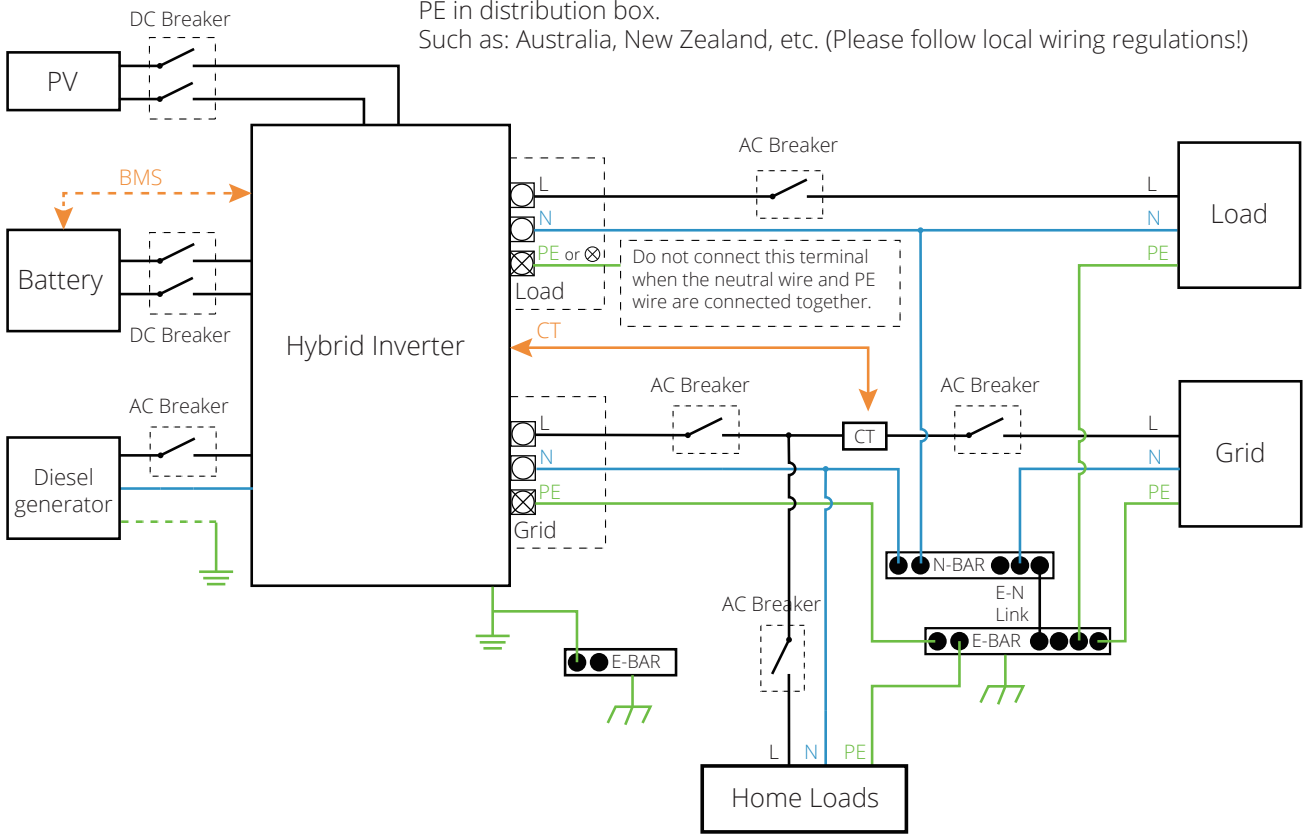

Typical Application of Diesel Generator

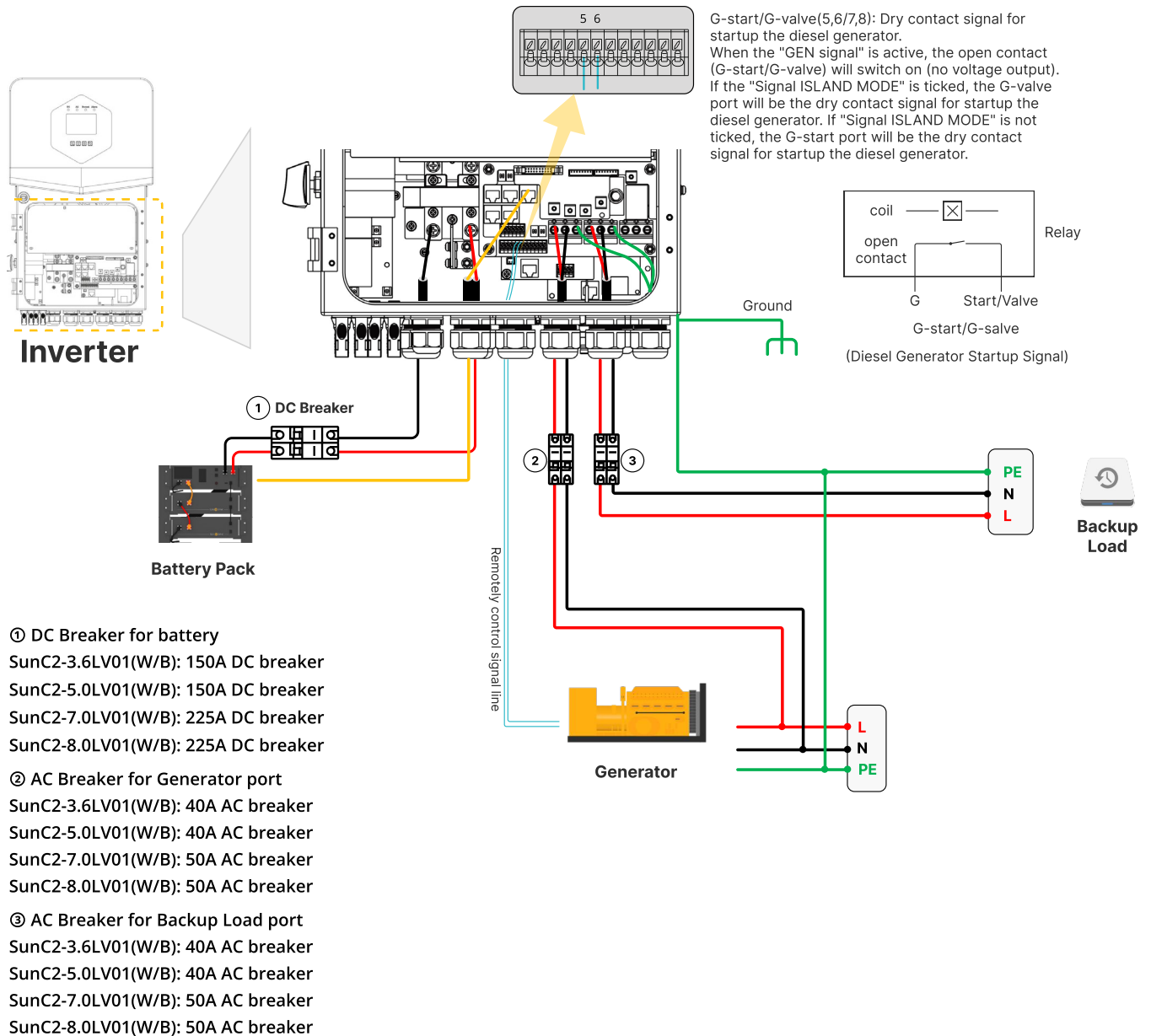

Single-Phase Parallel Connection

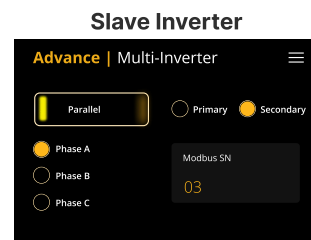
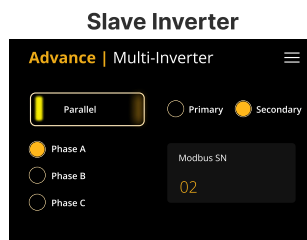
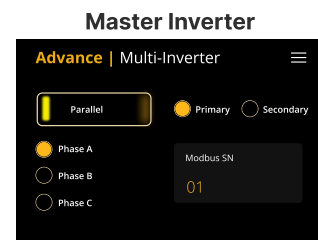
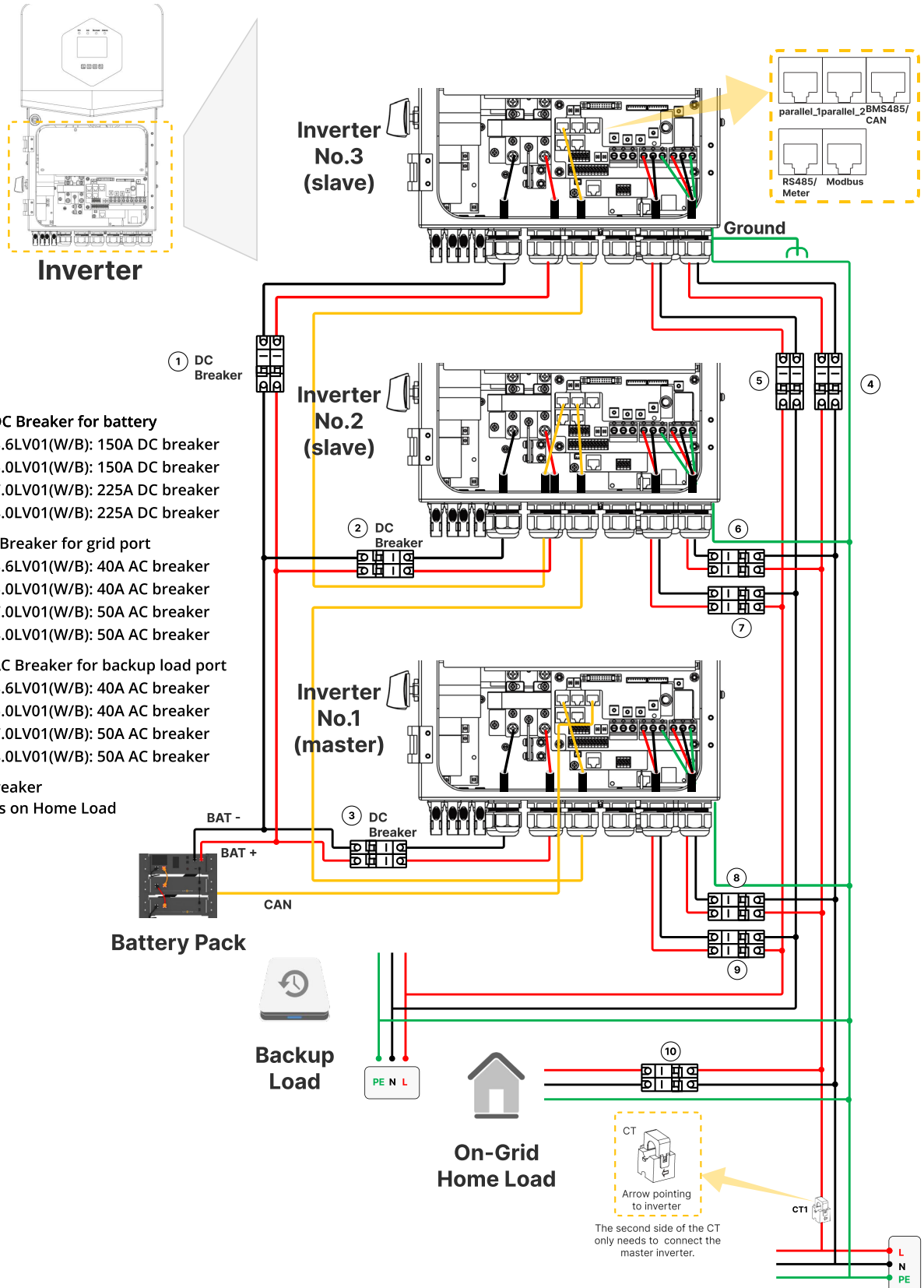

Single-Phase Parallel on Three-Phase Grid

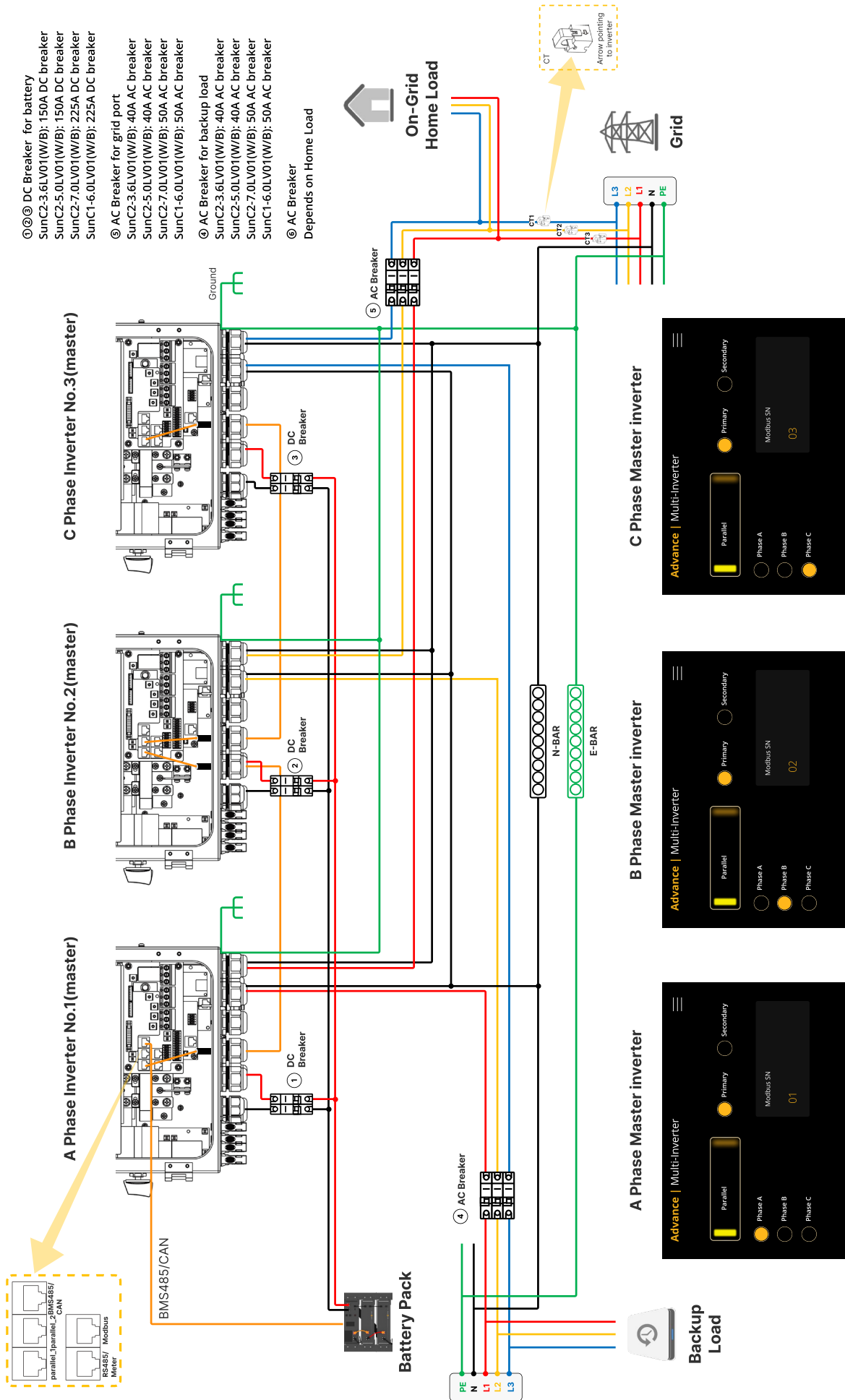

Single-Phase Grid-Tied Connection

- There are no active connections to the GEN and LOAD ports.
- Inverters cannot be connected in parallel configuration. Since there are no batteries, they can only operate with the GRID and SOLAR and will always remain synchronised when the grid is connected.
- Each inverter must be equipped with its own current transformers (CTs).
- All CTs must be installed before establishing the initial inverter connection to ensure comprehensive plant-wide monitoring.
- Each inverter is designed with a total of two Maximum Power Point Trackers (MPPTs), each capable of supporting two PV input strings. The current and voltage ratings for each input as well as the overall ratings per MPPT must be carefully considered.
- Details regarding DC breakers, AC breakers, fuses, photovoltaic (PV) components, surge protectors, and cable sizes are not specified.

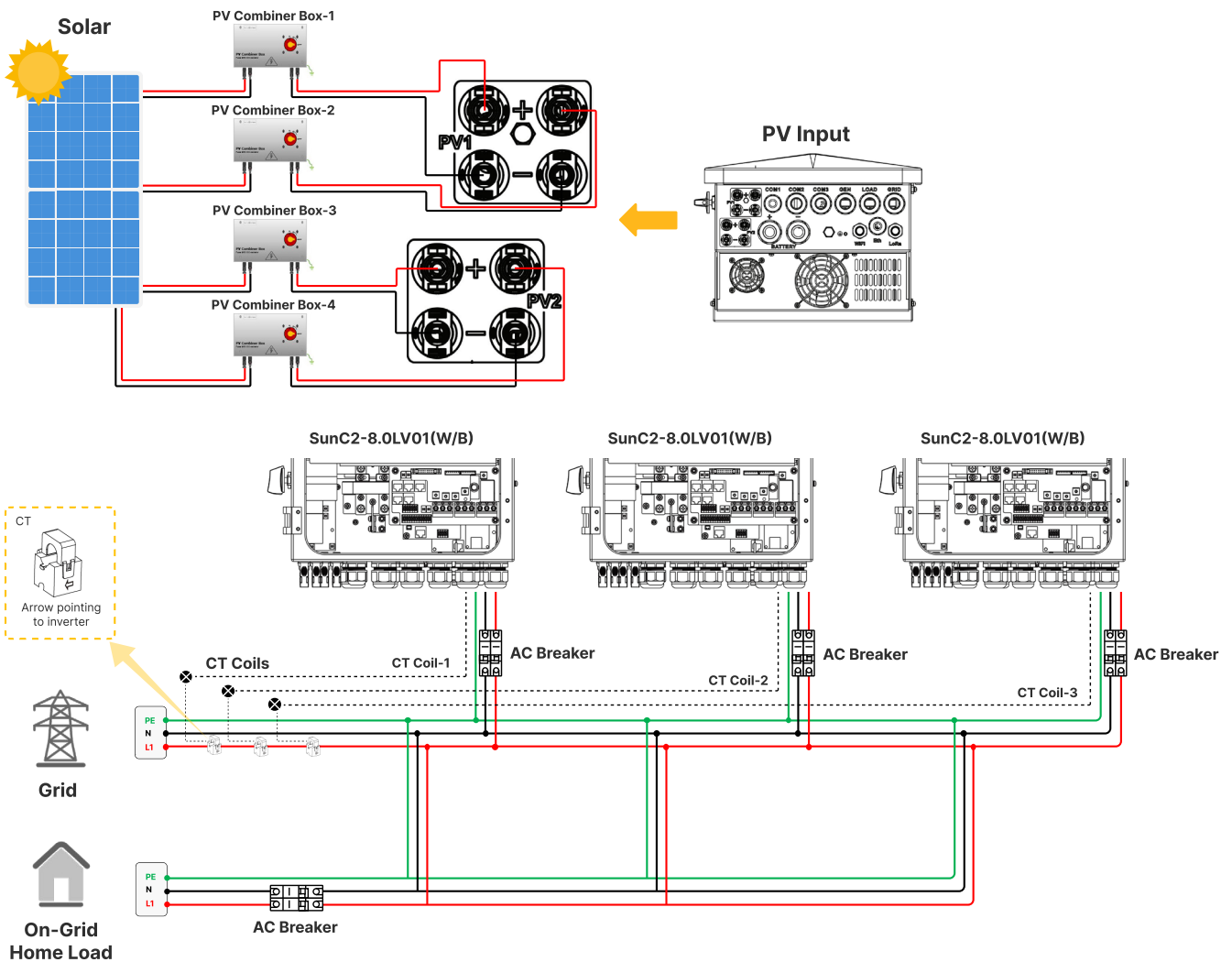

OPERATION

Switching ON/OFF

Before switching on the inverter, ensure that all wiring is complete and the battery connection is secure.

- To turn on the inverter, press the ON/OFF button located on the left side of the inverter case.
- When the inverter is powered by PV or grid supply but has no battery connected, the LCD screen will still illuminate, even if the ON/OFF button is off. The display will indicate that the system is in standby mode.
- In this state, press the ON/OFF button, then select 'No Battery' from the startup options. The system will begin operating using available PV or grid power only.



NOTICE

The inverter can operate without a battery if either PV or grid input is present. However, battery features such as backup and storage will not be available in this mode.

Display

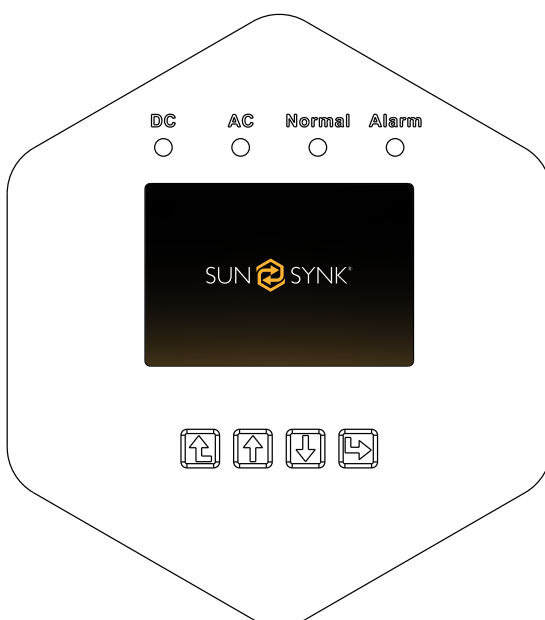

LED Indicators

LED Indicator		Meaning
DC	Green LED solid light	PV connection normal
AC	Green LED solid light	Grid connection normal
Normal	Green LED solid light	Inverter functioning normally
Alarm	Red LED solid light	Fault

Function Buttons

Function Key	Description
Esc	To exit the previous mode
Up	Increase the value of a setting
Down	Decrease the value of a setting
Enter	Confirm setting change (If not pressed each time the setting will not be saved)

LCD Operation Flow Chart

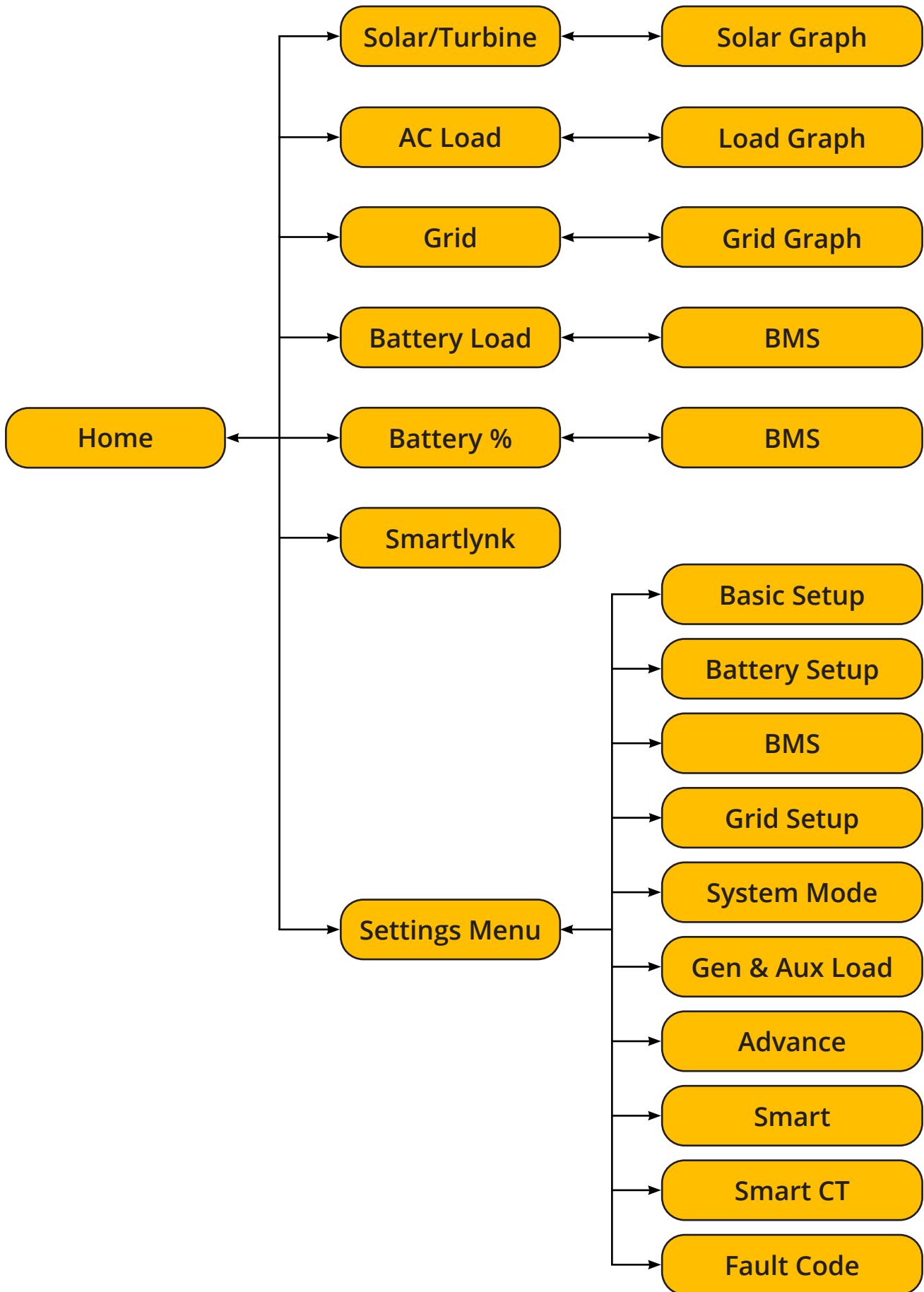

Home

The Home Screen serves as the central dashboard of the Acure Hybrid Inverter, providing users with an immediate and intuitive overview of the system's key metrics. From here, users can monitor the most important data, navigate to different sections, and control essential functions with ease.

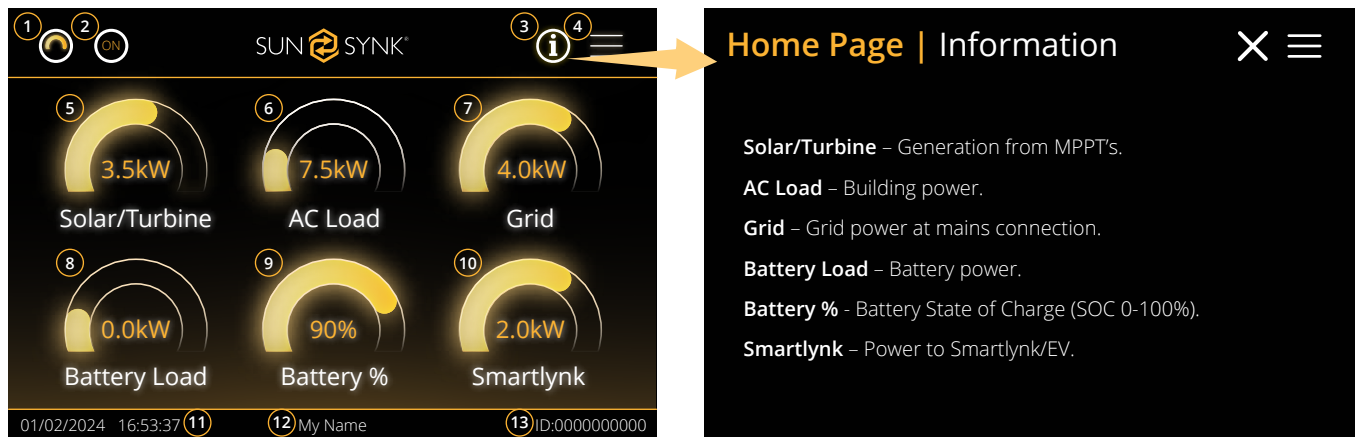

- 1 System Flow Icon: Tapping this icon opens the System Flow Chart screen, providing a visual map of how power is distributed between solar, battery, grid, and loads.
- 2 Smart Devices Icon: Leads to the Smart Devices screen, allowing users to interact with and monitor any connected smart devices.
- 3 Information Icon: Opens the Home Page Information screen, which explains each data icon.
- 4 Menu Icon: Leads to the main menu, where users can access setup options, smart features, advanced configurations, and more.
- 5 Solar/Turbine: Shows real-time energy generation from solar panels or turbine. Tap to access the Solar/Turbine Setup screen, which includes daily, monthly, yearly, and total solar generation stats.
- 6 AC Load: Displays the amount of power currently being used by the AC loads. Tap to access the AC Load screen for detailed usage monitoring.
- 7 Grid: Indicates the power being drawn from or exported to the grid. Tap to access the Grid screen and view energy import/export graphs over time.
- 8 Battery Load: Displays the real-time battery power flow. This value shows whether the battery is charging or discharging, in kilowatts. Tapping this icon opens the Li BMS (Battery Management System) screen, where users can monitor battery performance in greater detail.
- 9 Battery %: Indicates the State of Charge (SOC) of the battery, displayed as a percentage (0-100%). Tapping this icon also leads to the BMS screen.
- 10 Smartlynk: Displays the power directed to Smartlynk systems or EV charging. Tap to open the Smartlynk Setup screen and configure smart energy flow preferences.
- 11 Date & Time: Displays the current system date and time in real time (e.g., 01/02/2024 – 16:53:37).
- 12 Username: Indicates the name of the current user or administrator operating the interface (e.g., "My Name").
- 13 System ID: Displays the inverter's unique system identifier (e.g., ID:0000000000), useful for system tracking, service, and diagnostics.

Home | Solar/Turbine

The Solar/Turbine screen displays the total solar energy produced over various time periods. It provides a clear graphical breakdown of solar generation statistics by day, month, year, and overall system lifetime.

Access this screen by tapping the "Solar/Turbine" icon on the Home screen.

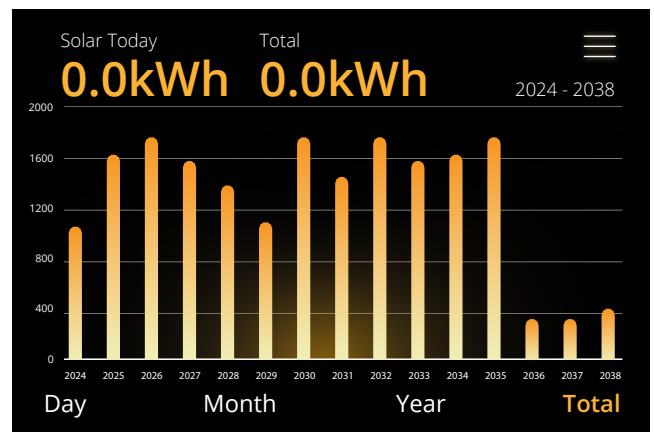
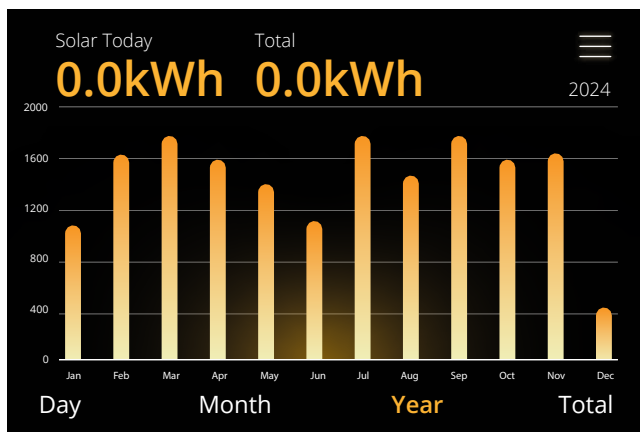
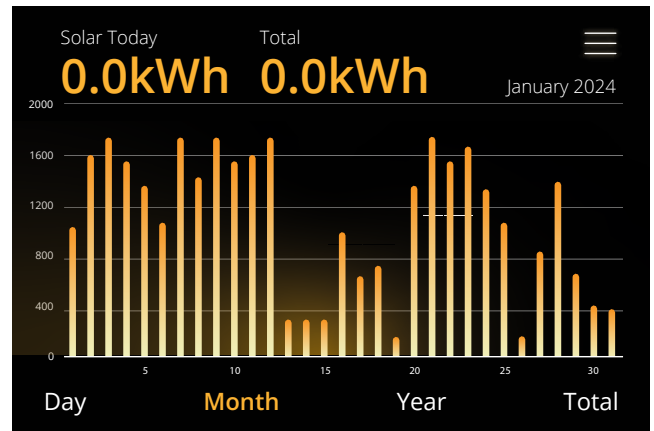
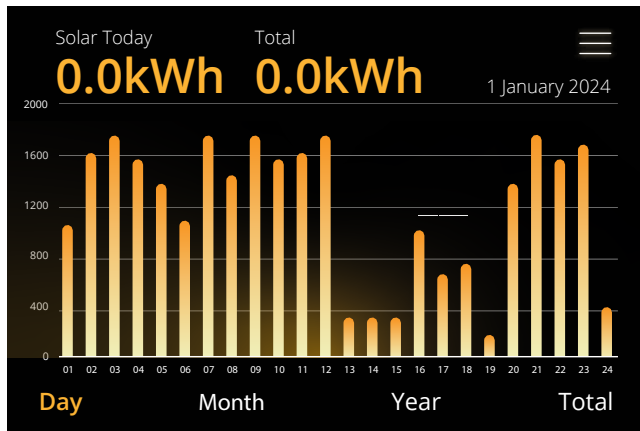

Home | AC Load

The AC Load screen provides a real-time overview of power flow across all major system components, including the battery, grid, solar PV input, inverter output, connected loads, and generator. This page is designed to give users a full picture of energy usage and system performance.

To access this page, tap the "AC Load" dial on the Home Screen.

Battery	Grid Power	Solar Power
-1559 Watts 93% (SOC) 54.58 V -28.57 Amps 25.0 C	2763 Watts 49.9 Hz 246 Volts 6.4 Amps CT: 2763 Watts LD: 1596 Watts	M1: 0 Watts 0 Volts 0.0 Amps M2: 0 Watts 0 Volts 0.0 Amps
Inverter Power	Load Power	GEN
-1637 Watts 49.9 Hz 247 Volts 6.6 Amps	1126 Watts 248 volts	0 Watts 0V/0.0 Hz

COLUMN DESCRIPTIONS

1. Battery Column: Displays total power from the battery, including SOC, voltage, current, and temperature.
 - A negative value indicates discharge.
 - A positive value indicates charging.
 - Temperature reads 0°C if the sensor is disconnected.
 - Displays internal temperatures from DC transformer and AC heatsink.
 - Values turn red at $\geq 90^{\circ}\text{C}$.
 - Performance begins degrading at 110°C and shuts down automatically for safety.

2. Grid Column: Shows power exchange with the grid.
 - Positive = importing power, Negative = exporting power.
 - Displays frequency, voltage, current, and CT coil value.
 - If PV is disconnected but power is still supplied from the grid, check CT coil polarity.
3. Solar Column (MPPT 1 & 2): Shows solar generation statistics for each Maximum Power Point Tracker.
 - Includes power, voltage, and current per MPPT input.
4. Inverter Column: Displays inverter output power, frequency, voltage, and current delivered to the system.
5. Load Column: Shows the total load power (W) and load voltage (V) drawn from the inverter.
6. GEN Column (Generator): Displays power output, voltage, and frequency of the connected generator (if active).

Home | Grid

The Grid screen provides a graphical overview of energy imported from and exported to the grid. Users can monitor grid activity over different time periods—daily, monthly, yearly, and total system lifetime—to better understand consumption patterns and export performance.

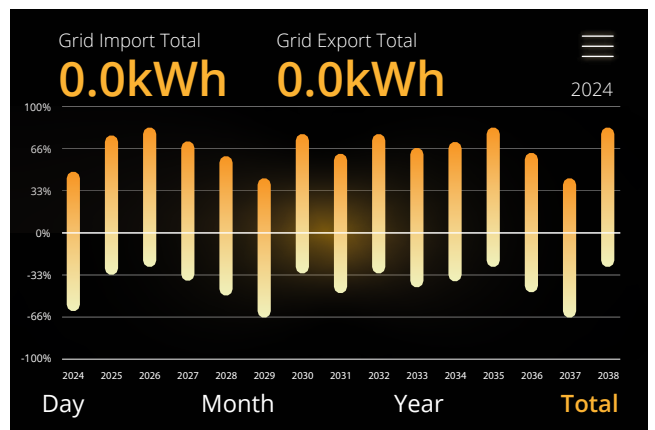
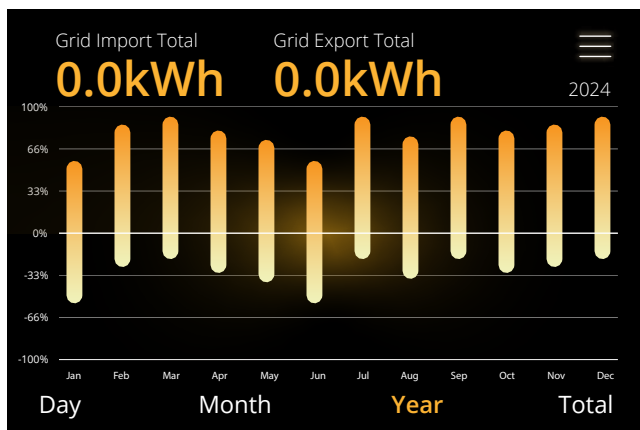
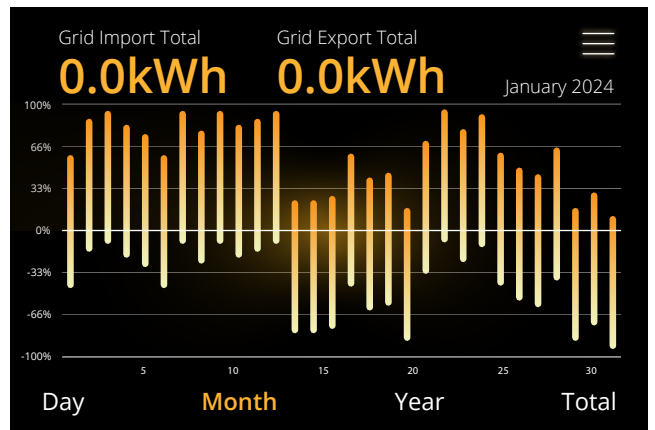
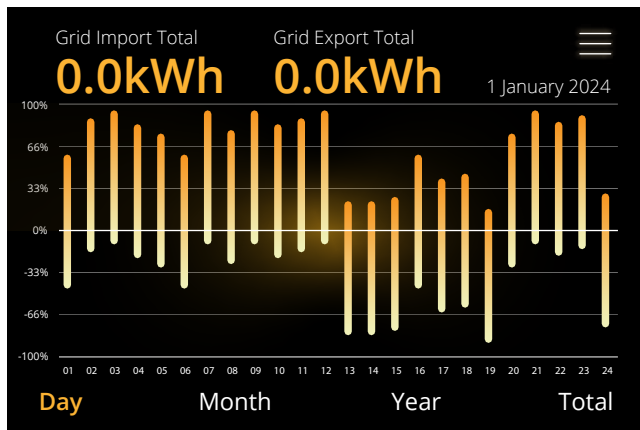

Access this screen by tapping the “Grid” icon on the Home screen.



Home | Battery Load and Battery %

This page displays detailed information from the Battery Management System (BMS). It allows users to monitor real-time battery performance, safety parameters, and individual cell behaviour.

Access this page by tapping the "Battery Load" or "Battery %" icon on the Home screen. All values are sourced directly from the connected battery's BMS.

Li BMS		 
Battery Voltage	53.06V	
Battery Current	-1A	
Battery Temperature	22.0C	
Total SOC	85%	
Total SOH	100%	
Battery Charge Voltage	58.0V	
Charge Current Limit	50A	
Discharge Current Limit	50A	
Alarms: 0x0000 0x0000		
Sum Data		Details Data

Li BMS								
	Volt	Curr	Temp	SOC	Energy	Charge		Fault
1	00.00V	00.00A	00.0C	00.0%	00.0Ah	0.0V	0.0A	0 0 0
2	00.00V	00.00A	00.0C	00.0%	00.0Ah	0.0V	0.0A	0 0 0
3	00.00V	00.00A	00.0C	00.0%	00.0Ah	0.0V	0.0A	0 0 0
4	00.00V	00.00A	00.0C	00.0%	00.0Ah	0.0V	0.0A	0 0 0
5	00.00V	00.00A	00.0C	00.0%	00.0Ah	0.0V	0.0A	0 0 0
6	00.00V	00.00A	00.0C	00.0%	00.0Ah	0.0V	0.0A	0 0 0
7	00.00V	00.00A	00.0C	00.0%	00.0Ah	0.0V	0.0A	0 0 0
8	00.00V	00.00A	00.0C	00.0%	00.0Ah	0.0V	0.0A	0 0 0
9	00.00V	00.00A	00.0C	00.0%	00.0Ah	0.0V	0.0A	0 0 0
10	00.00V	00.00A	00.0C	00.0%	00.0Ah	0.0V	0.0A	0 0 0
11	00.00V	00.00A	00.0C	00.0%	00.0Ah	0.0V	0.0A	0 0 0
12	00.00V	00.00A	00.0C	00.0%	00.0Ah	0.0V	0.0A	0 0 0
13	00.00V	00.00A	00.0C	00.0%	00.0Ah	0.0V	0.0A	0 0 0
14	00.00V	00.00A	00.0C	00.0%	00.0Ah	0.0V	0.0A	0 0 0
15	00.00V	00.00A	00.0C	00.0%	00.0Ah	0.0V	0.0A	0 0 0
Sum Data		Details Data						

1. Li BMS – Sum Data.

This panel provides a high-level summary of the battery's operating condition:

- Battery Voltage: Total voltage of the battery pack (e.g., 53.06V)
- Battery Current: Positive = charging, Negative = discharging (e.g., -1A = discharge)
- Battery Temperature: Internal temperature in °C (e.g., 22.0°C)
- Total SOC: State of Charge – current battery level (e.g., 85%)
- Total SOH: State of Health – battery lifespan status (e.g., 100%)
- Battery Charge Voltage: Target voltage for charging (e.g., 58.0V)
- Charge Current Limit: Max current allowed when charging (e.g., 50A)
- Discharge Current Limit: Max current allowed when discharging (e.g., 50A)
- Alarms: Active alarm codes from the BMS, if any (e.g., 0x0000 0x0000 = no fault)

Tap the "Details Data" button to access deeper, cell-level insights.

2. Li BMS – Details Data.

This panel breaks down real-time readings from each individual battery cell:

- Volt: Voltage of each battery cell
- Curr: Current through each cell
- Temp: Temperature of each cell (°C)
- SOC: Charge level per cell (%)
- Energy: Energy in amp-hours (Ah) per cell
- Charge: Charging voltage and current
- Fault: Bit-level fault indicators per cell

Cells are listed numerically (1 to 15 or more depending on the battery pack), allowing precise identification of imbalance, faults, or temperature anomalies.

Tap "Sum Data" to return to the general overview.

Menu

The Menu Screen provides users with access to the core settings and configuration options of the Acure Hybrid Inverter. From here, users can navigate to important sections like System Setup, Quick Control, and Settings. This screen is essential for managing the system's functionality and viewing system diagnostics.

Access this screen by tapping the "Menu" icon on the Home Screen.

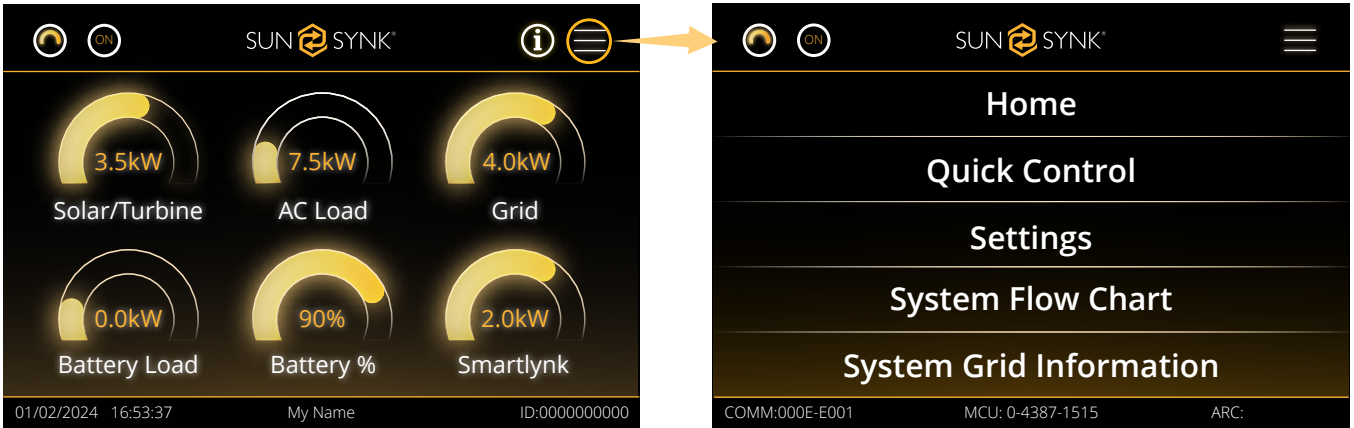

MENU OPTIONS

Once you tap the Menu icon, a dropdown screen appears with the following options:

- Home: Returns you to the Home Screen where you can view real-time system status and power flow information.
- Quick Control: Provides fast access to commonly used control options and system settings, such as turning the inverter on/off or adjusting power output.
- Settings: Opens the Settings Menu for detailed configuration options, including battery, grid, inverter settings, and more.
- System Flow Chart: Displays a system flow chart that shows the power generation and distribution process in a graphical format. This is helpful for understanding how energy flows between the inverter, battery, grid, and loads.
- System Grid Information: Provides detailed information about grid connection, including voltage, frequency, and energy exchange between the system and the grid.

Menu | Quick Control

The Quick Control screen provides immediate access to several critical inverter functions, allowing users to quickly toggle settings for specific operational needs. This screen enables quick adjustments to the system, ensuring efficient performance and control when needed.

Access this screen by tapping the "Quick Control" option in the Menu.

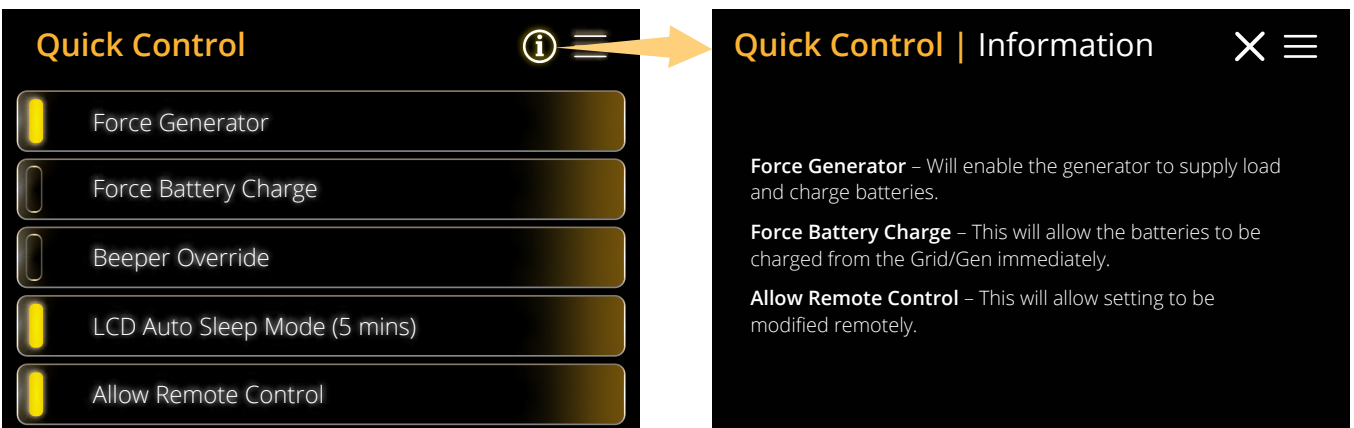

Menu | Settings

The Settings screen provides access to various configuration and diagnostic menus. Each menu item allows users to navigate to specific areas of the system to customize settings, perform system checks, and adjust operational parameters. This screen is critical for in-depth system management.

Access this screen by tapping the “Settings” option in the Menu.

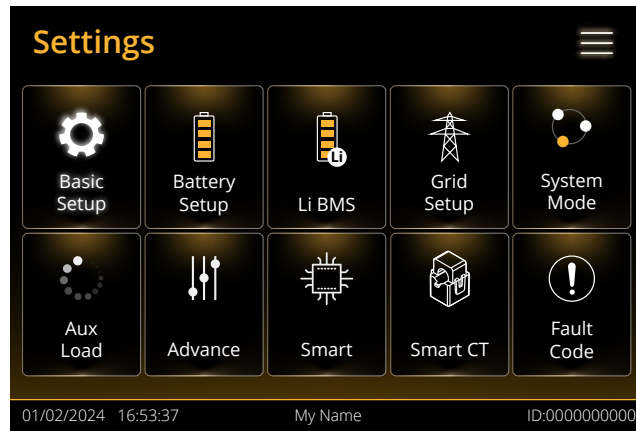

Menu | System Flow Chart

The System Flow Chart screens provide visual representations of how energy flows within the system, tailored to specific installation configurations. These charts allow users to understand and monitor how power is distributed among key components of the system, such as solar panels, batteries, inverters, and loads, under various operating conditions.

Access this screen by tapping the “System Flow Chart” option in the Menu.

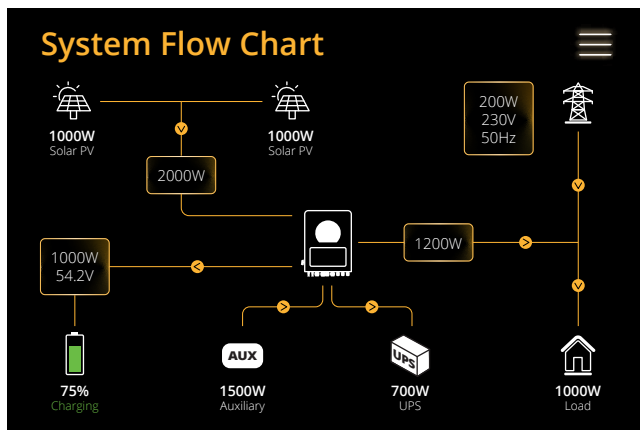

Auxiliary

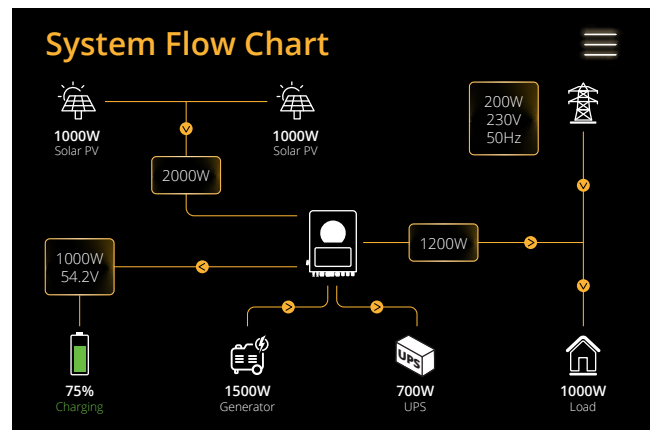

Generator

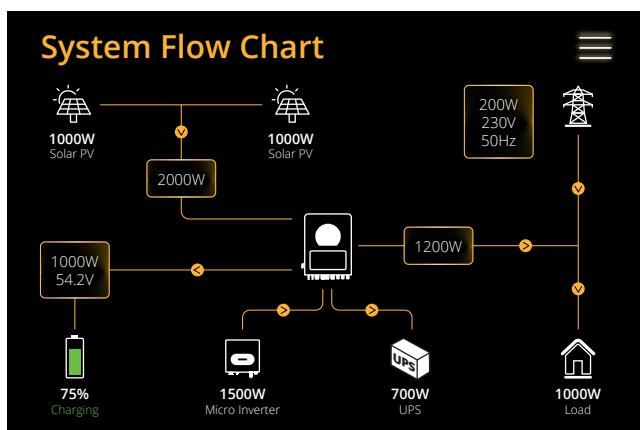

Micro Inverter

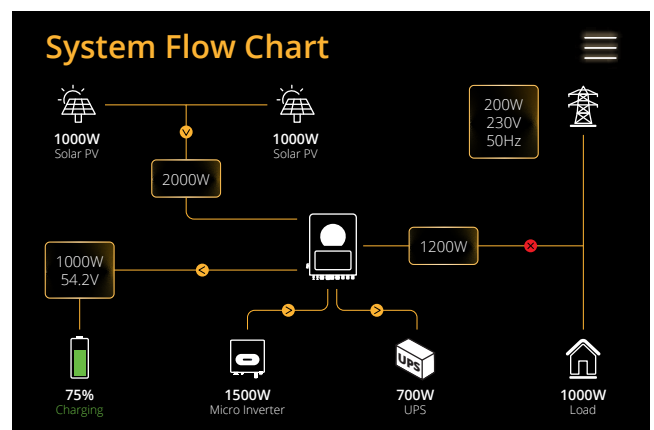

Grid Disconnected from Inverter

Menu | System Grid Information

The System Grid Information screen provides detailed insights into the daily, monthly, yearly, and total energy exchanged with the grid. It displays whether power is being imported from or exported to the grid. This page is crucial for understanding grid interaction, monitoring energy usage, and tracking power consumption or generation over time.

Access this screen by tapping the “System Grid Information” option in the Menu. This information is already shown in the Home | Grid page section (page 46).

Setup Page

The Setup Page provides users with direct access to a variety of system configuration options and diagnostic menus. This page serves as the hub for all advanced system settings, allowing users to quickly navigate to different sections for in-depth system management.

Access this page by tapping the “Settings” option from the Menu.

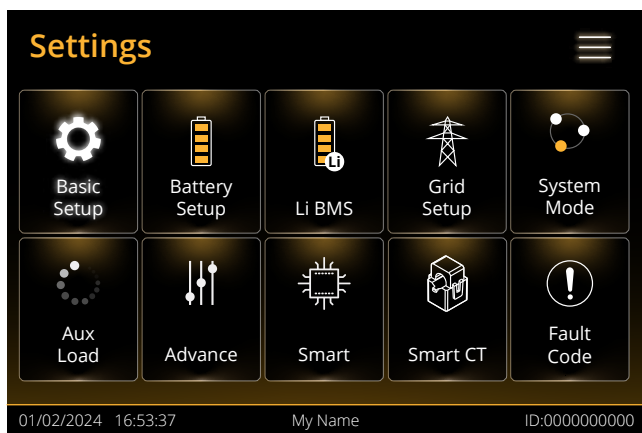

What you can do from this page:

- Basic Setup Page: Configure initial system settings, including network and preferences.
- Battery Setup Page: Adjust battery settings like charge limits and voltage.
- BMS Page: View battery health, charging, and discharging status.
- Grid Setup Page: Configure grid settings, such as voltage and frequency.
- System Mode Page: Select operating modes (on-grid, off-grid, UPS).

- Aux Load Page: Manage auxiliary loads connected to the system.
- Advance Page: Access advanced system configurations.
- Smart Page: Configure smart energy management features.
- Smart CT Page: Manage current transformer (CT) settings.
- Fault Code Page: Access system error logs and fault codes.

Basic Setup

The Basic Setup screen allows users to configure essential system settings for the inverter.

Access this page by tapping the “Basic Setup” option in the Setup Menu.

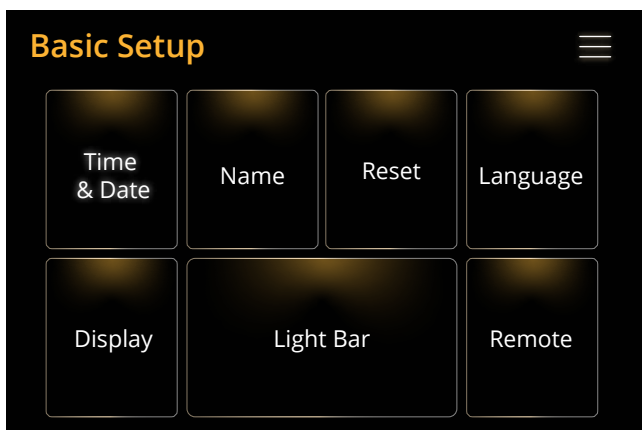

What you can do from this page:

- Set Time & Date: Adjust the system's time and date settings.
- Set System Name: Customize the name of the inverter system.
- Factory Reset: Restore the system settings to factory defaults.
- Set Language: Choose the preferred language for the system interface.
- Set Display Functions: Configure display settings, such as brightness and screen timeout.

- Set Light Bar (Status Mode): Adjust the status mode for the light bar indicator on the inverter.
- Allow Remote Control: Enable or disable remote control access for the system.

Basic Setup | Time & Date

The Time & Date screen allows users to configure the current system time and date. This is essential for accurate system logging, scheduling, and synchronization with other devices.

Access this page by tapping the “Time & Date” option under Basic Setup.

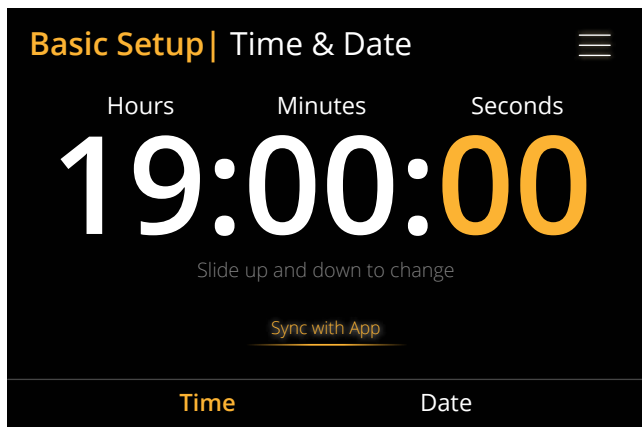

Time Settings:

- Adjust / set hours: Tap to set the current hour for the system clock.
- Adjust / set minutes: Tap to adjust the minute of the system time.
- Adjust / set seconds: Tap to set the seconds of the system time.
- Sync with App: Tap to sync the system’s time with a connected mobile app for automatic time adjustments.

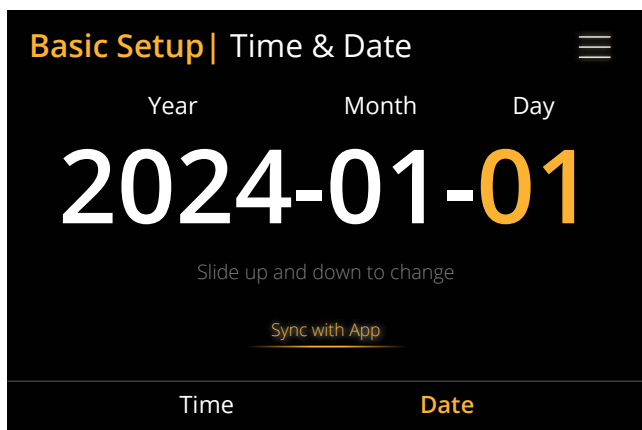

Date Settings:

- Adjust / set year: Tap to adjust the year for the system clock.
- Adjust / set month: Tap to adjust the month of the system date.
- Adjust / set day: Tap to set the day of the system date.
- Sync with App: Tap to sync the system’s date with a connected mobile app for automatic date adjustments.

Basic Setup | Name

The Name Setup screen allows users to set or change the system name. This name can be used to identify the inverter in the system’s settings or for network identification.

Access this page by tapping the “Name” option under Basic Setup.



What you can do from this page:

- Set a unique system name (up to ten characters).
- Tap “Click to set” to begin entering the name.
- Use the on-screen keyboard to input the name.
- The system supports both letters and numbers.
- Select characters using the arrow keys below the on-screen keyboard.
- If necessary, edit or clear the existing name by using the keyboard controls.

Basic Setup | Reset

The Reset Setup page allows users to reset the system or lock certain settings for security and configuration purposes.

Access this page by tapping the “Reset” option under Basic Setup.

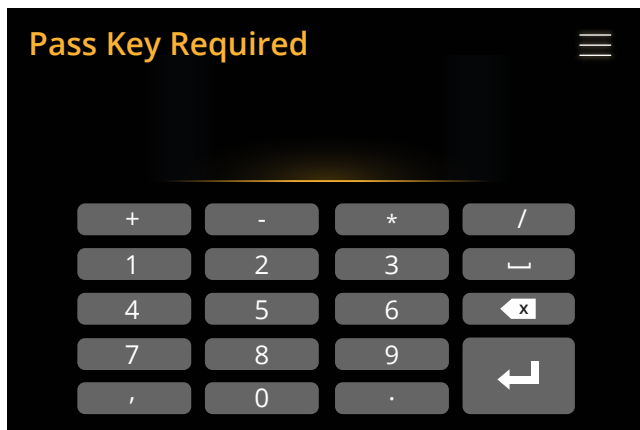
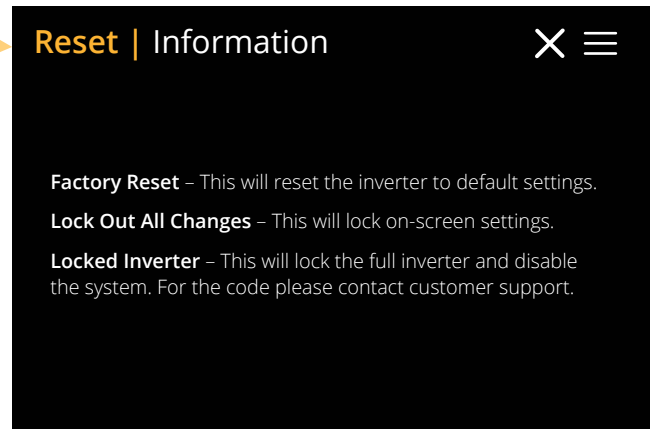

- Factory Reset: Reset the inverter to default settings.
- Lock Out All Changes: Lock all on-screen settings.
- Locked Inverter: Lock the full inverter system and disable operation.

*Before performing a successful 'Factory Reset' and locking the systems, the user must enter a password to allow the setting to take place. The password for 'Factory Reset' is 9999 and for lockout is 7777.

Basic Setup | Language

The Language Setup screen allows users to select the default language for the inverter interface.

Access this page by tapping the “Language” option under Basic Setup.

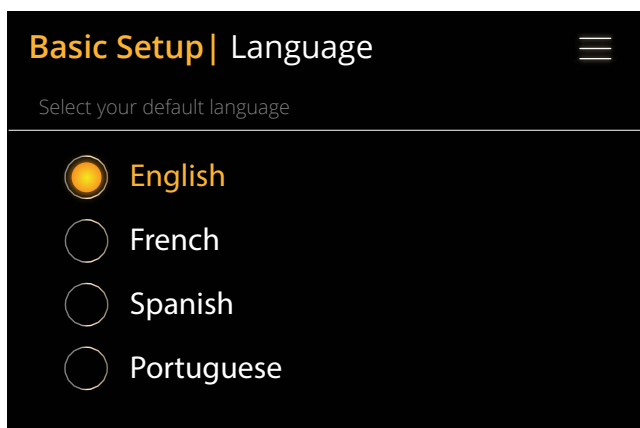

What you can do from this page:

- Select your default language.

Basic Setup | Display

The Display Setup screen allows users to configure the display settings of the inverter, including brightness, sleep mode, and beep sound preferences.

Access this page by tapping the “Display” option under Basic Setup.

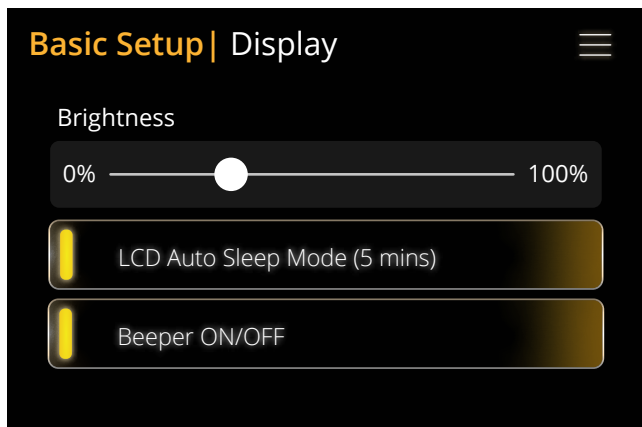

What you can do from this page:

- Set the Display Brightness: Adjust the brightness level of the LCD display from 0% to 100%.
- Switch the LCD Auto Sleep Mode (5 mins): Enable or disable the LCD Auto Sleep Mode, which automatically turns off the display after 5 minutes of inactivity.
- Switch the Beeper ON/OFF: Turn the beeper sound ON or OFF to manage audio alerts from the inverter.

Basic Setup | Light Bar | Status Mode

The Light Bar | Status Mode screen allows users to configure the light bar that visually indicates the inverter’s operating status. The light bar can display different colours based on system conditions such as battery charge, grid connection, and load status.

Access this page by tapping the “Light Bar” option under Basic Setup.

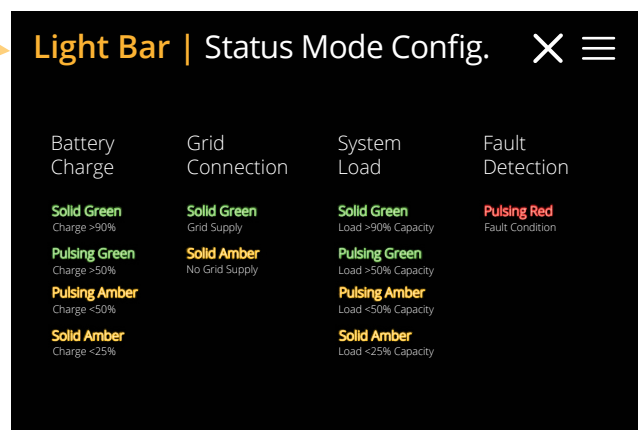
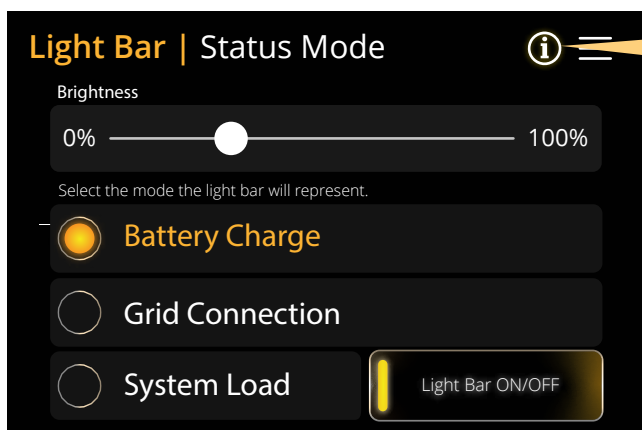

What you can do from this page:

- Set the Light Bar Brightness: Adjust the brightness level of the light bar from 0% to 100%.
- Select the Mode the Light Bar Will Represent.
- Clicking on the Info Icon (top right of the screen) allows further configuration of the status mode settings.

Basic Setup | Remote

The Remote Setup page allows users to enable or disable the Remote Control function. This feature allows the inverter to be controlled remotely from another device, such as a mobile app or web portal.

Access this page by tapping the "Remote" option under Basic Setup.

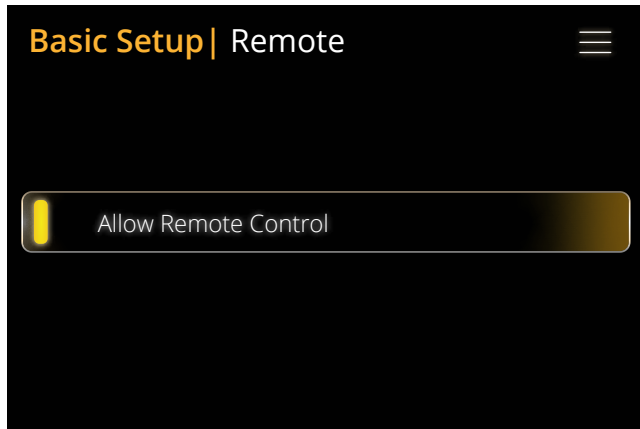

What you can do from this page:

- Enable Remote Control: Turn the Remote Control function ON to allow control of the inverter remotely. When enabled, the inverter can be managed from an external device.

Battery Setup

The Battery Setup page allows users to configure key settings related to the battery type, charging parameters, and shutdown settings.

Access this page by tapping the "Battery Setup" option in the Setup Menu.

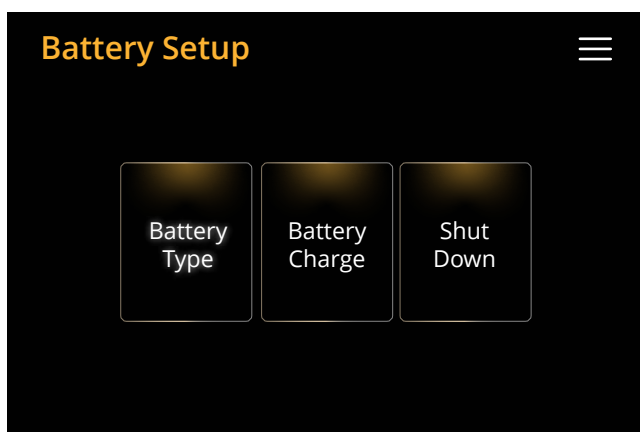

What you can do from this page:

- Set Up the Battery Type: Configure the type of battery used (e.g., lithium, lead-acid, etc.).
- Set Up the Battery Charge: Adjust the charging parameters, including charge voltage and current settings.
- Set Up the Shut Down: Configure shutdown parameters for the battery, such as voltage or temperature thresholds.

Battery | Type

The Battery Type page allows users to select the appropriate battery type for their system, based on the battery configuration and the type of Battery Management System (BMS) used.

Access this page by tapping the "Type Options" under Battery Setup.

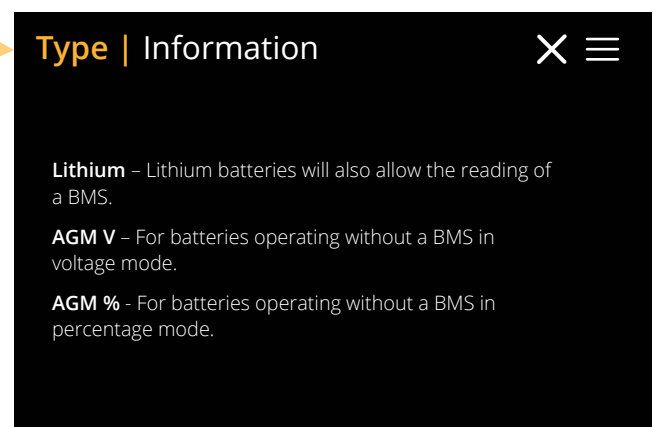
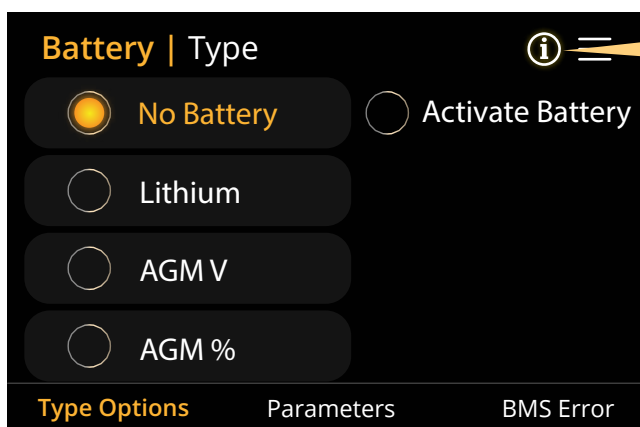

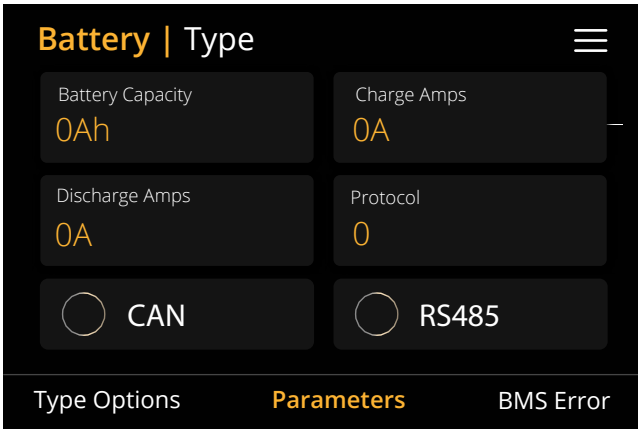

After select the appropriate battery type, access the "Capacity/Discharge" tab under Battery Setup. This page allows users to set up key parameters for battery capacity, charge/discharge current, and communication protocols.

What you can do from this page:

- Battery Capacity (Ah): For non-BMS-batteries the range allowed is 0-2000Ah, while for lithium-ion, the inverter will use the capacity value of the BMS.
- Charge/Discharge Amps: The Max battery charge/discharge current (0-90A for 3.6kW model, 0-120A for 5kW model, 0-135A for 6kW model).
- Protocol: Select the communication protocol for the battery system (CAN or RS485).

Additionally, users can enable or disable the BMS Error feature, which manages errors related to the Battery Management System (BMS).

What you can do from this page:

- Enable BMS Error: Enable or disable the BMS Error feature. If active, when the BMS fails to communicate with the inverter, the inverter will stop working and report a fault.

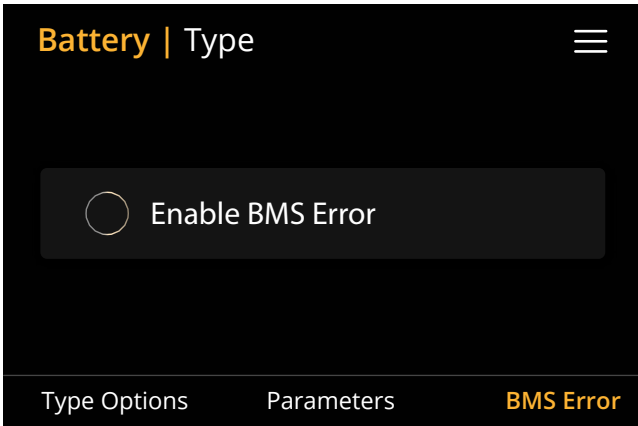

After that, a notification message will appear to confirm the information. So please check!

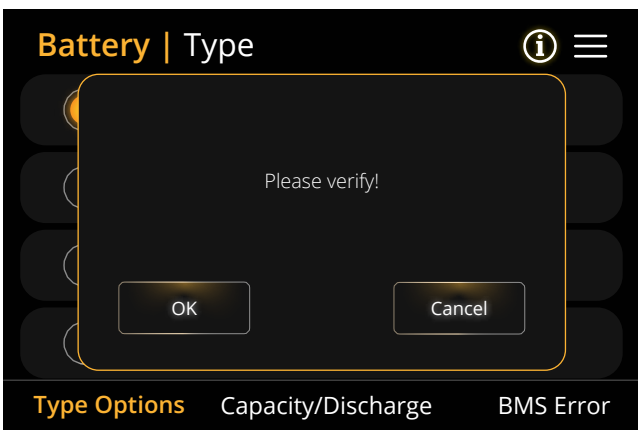

Battery | Charge

The Battery Charge Configuration page allows users to select the charging source for the battery, either from the generator (Gen) or the grid, as well as configure associated signals.

Access this page by tapping the " Battery Charge" option under Battery Setup.

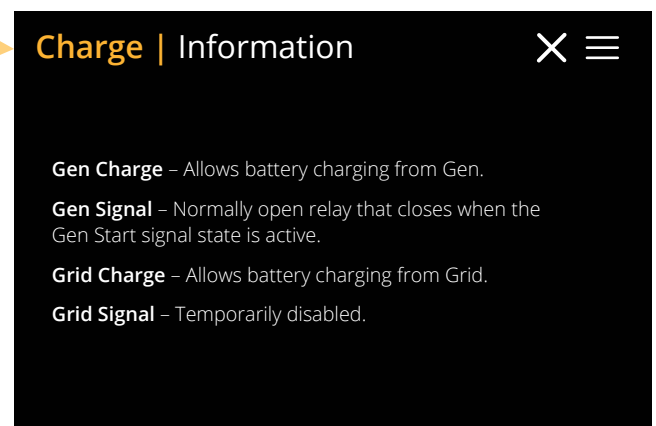
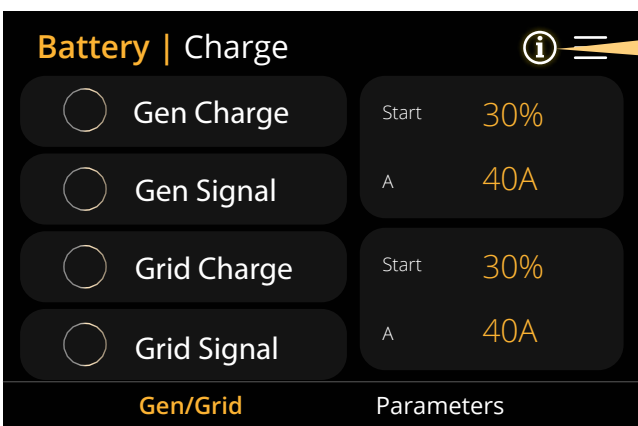

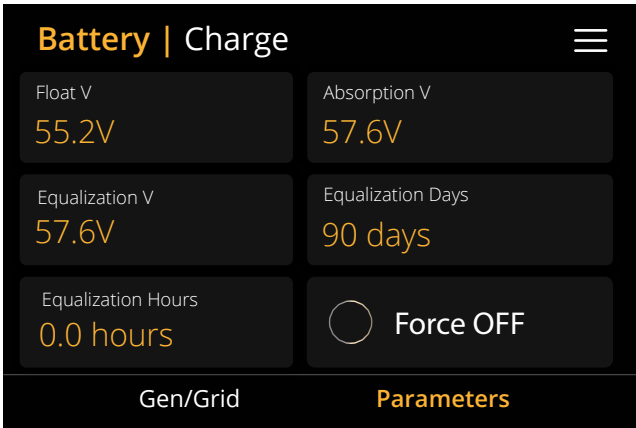

The Battery Charge Parameters page allows users to configure specific charge settings for the battery, such as charge rate, float voltage, absorption voltage, and equalization voltage.

What you can do from this page:

- Amps: Set the charge rate (e.g., 40A from the generator, 38A from the grid).
- Float V: Set the voltage at which the battery is maintained after being fully charged. For AGM batteries, the Float V is 55.20V.

- Absorption V: Set the level of charge that can be applied to the battery without overheating. For AGM batteries, the Absorption V is 57.60V.
- Equalization V: Set the equalizing charge to remove sulphate crystals from lead-acid batteries. For AGM batteries, the Equalization V is 58.80V.
- Force OFF: Disables any forced charging, ensuring that the generator or grid is not forced to start under non-ideal conditions.



WARNING

Do not alter these settings too often on the same battery, as it may cause damage.

RECOMMENDED BATTERY SETTINGS

The following settings are recommended for different types of batteries to ensure proper charging and safe operation:

Battery Type	Absorption Stage	Float Stage	Voltage (every 30 days 3hr)
AGM (or PCC)	14.2V (57.6V)	13.4V (53.6V)	14.2V (57.6V)
Gel	14.1V (56.4V)	13.5V (54.0V)	
Wet	14.7V (59.0V)	13.7V (55.0V)	14.7V (59.0V)
Lithium	Follow its BMS voltage parameters		



NOTICE

Recommended:

AGM and Flooded: Ah battery size x 20% = Charge/Discharge amps.

Lithium: Ah battery size x 50% = Charge/Discharge amps.

Gel: follow manufacturer's instructions.

A generator can either be connected to the Grid side or to the Gen connection. When connected to the Grid Input, the inverter will consider the power coming from the generator as 'Grid Supply'. Users should ensure this power goes to the LOAD only and should not be exported to other outlets, as this will damage the generator.

If the generator is connected to the inverter and a generating signal exists, the inverter will switch 100% of the load to the generator and then slowly increase the charging currents to the batteries. Therefore, the generator must be able to supply both the charge current and the total load current.

The generator can be controlled via a relay with a set of dry-contacts to enable remote control. The current on the contacts is limited to approximately 1Amp 12V.

Below is a simple reference circuit of an auto-start system that can auto-start generators on a boat. (Sunsynk will be releasing a new OS E406 (Auto-Start) for better generator control).

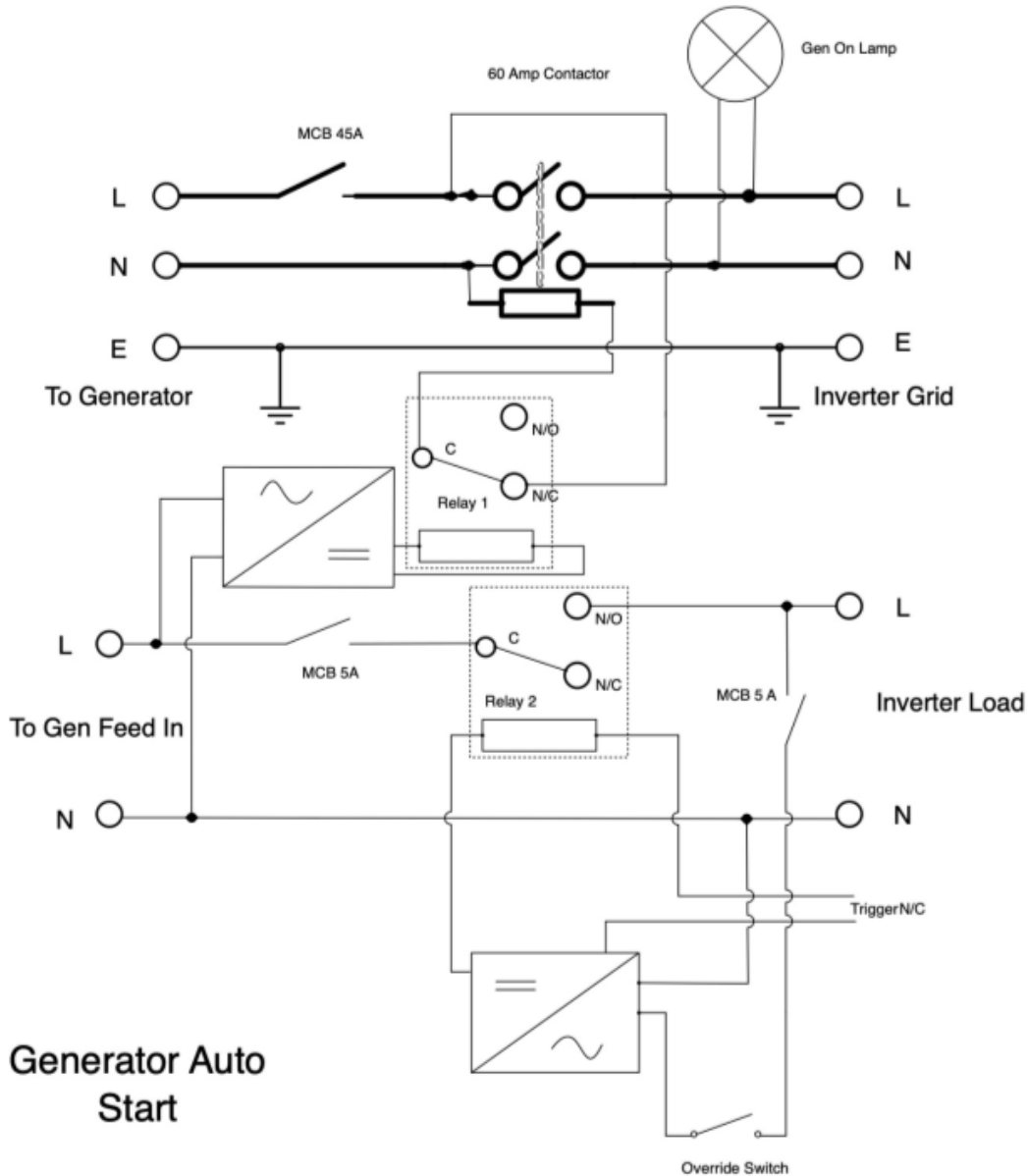

Battery | Shut Down

The Battery Shut Down page allows you to set the thresholds for when the inverter should shut down, alert the user about low battery, or restart. These settings ensure proper battery management and prevent excessive discharge that could harm the battery.

Access this page by tapping the “Shut Down” option under Battery Setup.

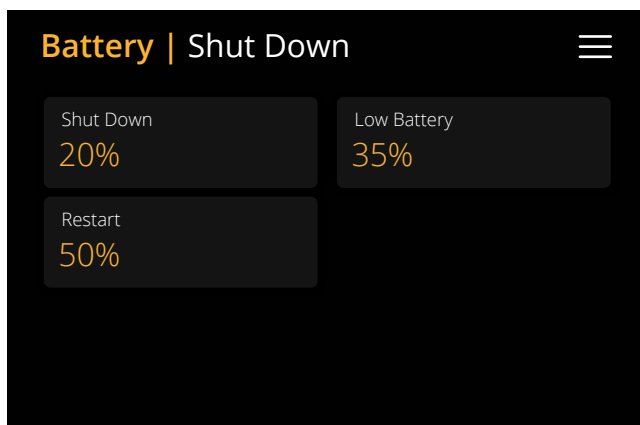

What you can do from this page:

- Shut Down 20%: This setting indicates that the inverter will shut down if the SOC falls below 20%.
- Low Battery 35%: This setting triggers an alarm when the SOC drops below 35%.
- Restart 50%: The inverter will restart AC output when the battery voltage reaches 50% of its capacity, ensuring proper functioning once the battery has been sufficiently recharged.



NOTICE

Activating Shutdown causes the inverter to enter standby mode. It does not fully turn off the inverter. The total shutdown occurs only when battery voltage drops below 19V.

The voltage shown on the Sunsynk Parity Inverter varies depending on whether the inverter is charging or discharging the batteries.

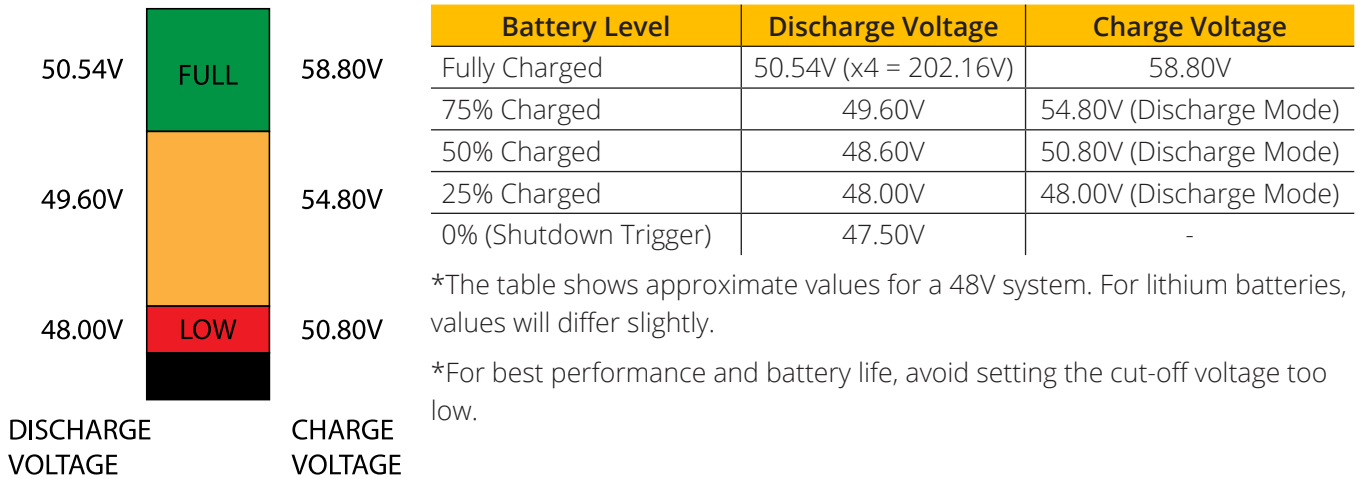

The Sunsynk inverter is compatible with AGM Lead Acid and Lithium Battery Banks. Below is a brief explanation of each:

1. AGM (Absorbent Glass Mat):
 - A sealed lead-acid battery design with internal mats that absorb and immobilise electrolyte.
 - Ideal for deep-cycle applications.
2. Lithium (LiFePO₄):
 - Longer lifespan and high efficiency.
 - Must use manufacturer-defined charging profiles.

STATE OF CHARGE

1. Bulk Stage:
 - Delivers a large current to restore most of the battery's capacity (~80%).
 - Continues until voltage reaches the set absorption level.
 - The proper charger supplies current based on the battery's Ah rating.
2. Absorption Stage:
 - Voltage is held at a higher level to complete the final 20% of the charge.
 - Required to fully saturate the battery and avoid sulfation.
 - Typical AGM absorption voltage: 14.1V – 14.8V DC (depending on model).
3. Float Stage:
 - Voltage is reduced to 13.0V – 13.8V DC to maintain the charge without overcharging.
 - Ensures battery is ready for use while preserving lifespan.
4. Equalisation (Lead-Acid only):
 - Periodically increases voltage above normal levels to desulphate the battery plates.
 - Not used with lithium batteries.
 - AGM batteries benefit from this occasionally if recommended by the manufacturer.

Battery Management System (BMS)

After installing a lithium battery, verify that communication between the battery and the inverter is working properly. To do this:

1. Tap the BMS icon on the screen.
2. Check whether the battery information appears correctly.

If no data or incorrect data is displayed (as shown in the examples below), a communication error has occurred.

Li BMS			
Battery Voltage	53.06V		
Battery Current	-1A		
Battery Temperature	22.0C		
Total SOC	85%		
Total SOH	100%		
Battery Charge Voltage	58.0V		
Charge Current Limit	50A		
Discharge Current Limit	50A		
Alarms: 0x0000 0x0000			
Sum Data		Details Data	

Li BMS								
	Volt	Curr	Temp	SOC	Energy	Charge	Fault	
1	00.00V	00.00A	00.0C	00.0%	00.0Ah	0.0V	0.0A	0 0 0
2	00.00V	00.00A	00.0C	00.0%	00.0Ah	0.0V	0.0A	0 0 0
3	00.00V	00.00A	00.0C	00.0%	00.0Ah	0.0V	0.0A	0 0 0
4	00.00V	00.00A	00.0C	00.0%	00.0Ah	0.0V	0.0A	0 0 0
5	00.00V	00.00A	00.0C	00.0%	00.0Ah	0.0V	0.0A	0 0 0
6	00.00V	00.00A	00.0C	00.0%	00.0Ah	0.0V	0.0A	0 0 0
7	00.00V	00.00A	00.0C	00.0%	00.0Ah	0.0V	0.0A	0 0 0
8	00.00V	00.00A	00.0C	00.0%	00.0Ah	0.0V	0.0A	0 0 0
9	00.00V	00.00A	00.0C	00.0%	00.0Ah	0.0V	0.0A	0 0 0
10	00.00V	00.00A	00.0C	00.0%	00.0Ah	0.0V	0.0A	0 0 0
11	00.00V	00.00A	00.0C	00.0%	00.0Ah	0.0V	0.0A	0 0 0
12	00.00V	00.00A	00.0C	00.0%	00.0Ah	0.0V	0.0A	0 0 0
13	00.00V	00.00A	00.0C	00.0%	00.0Ah	0.0V	0.0A	0 0 0
14	00.00V	00.00A	00.0C	00.0%	00.0Ah	0.0V	0.0A	0 0 0
15	00.00V	00.00A	00.0C	00.0%	00.0Ah	0.0V	0.0A	0 0 0
Sum Data		Details Data						

If a BMS communication issue is detected:

1. Check that the data cable is the correct type (e.g., RS485, CAN, or manufacturer-specific).
2. Ensure the cable is connected properly into the appropriate BMS communication port.

Some battery manufacturers use communication protocols other than RS485 (such as CAN). Refer to the battery manual for exact connection requirements.



NOTICE

Some lithium batteries cannot be controlled directly by the Sunsynk inverter via BMS. If communication is not possible:

1. Treat the battery as a lead-acid battery in the inverter settings.
2. Manually configure the charging and discharging values based on the battery manufacturer's recommendations.

It is crucial to refer to the manuals that manufacturers produce for their batteries. That way, the chance of errors occurring during installation is significantly reduced. The table below lists lithium batteries that have been tested and approved by Sunsynk for 48V inverters. These are verified for proper communication and functionality.

Brand	Model	48V Storage Inverter	RS485 or CAN	Inverter Setup	Notes
DYNESS	B4850	✓	CAN	0	
	POWERBOXF			0	
	A48100			0	
SunketESS	LFP5000	✓	CAN	0	
Osily	LFP5KWH/LV	✓	CAN	0	
HUBBLE	AM-2 5.5KW	✓	CAN	0	CANH = Pin 4 CANL = Pin 5
	AM-5		CAN	0	
	AM-10		CAN	0	
	Blade 7kWh		CAN	0	

Brand	Model	48V Storage Inverter	RS485 or CAN	Inverter Setup	Notes
SACRED SUN	SSIF2P15S48100C	✓	RS485	1	Cut Line 3, 6, 8
	FCIFP48100A		RS485	1	
	SSIFP48100A		RS485	1	
SHOTO	SDC-Box5(5.12KWH)	✓	CAN	0	
SolarMD	SS4074	✓	CAN	0	To be used with V2 Logger http://solarmd.co.za/inverter-compatibility-solarmd/sunsynk-and-solar-md/
	SS4037			0	
	SS202			0	
	SS4143			0	
	SS4083			0	
	SS214			0	
PYLON	US2000B	✓	CAN	0	
			RS485	12	
	US3000		CAN	0	
			RS485	12	
	US2000C		CAN	0	
			RS485	12	
	US3000C		CAN	0	
			RS485	12	
	UP5000		CAN	0	
			RS485	12	
	US5000		CAN	0	
			RS485	12	
Force L1	CAN	0			
	RS485	12			
Force L2	CAN	0			
	RS485	12			
UZ ENERGY	L051100-A	✓	CAN	0	
	L051100-A1		CAN	0	
	L051100-B		CAN	0	
	L051100-D		CAN	0	
GenixGreen	ESS-5120	✓	RS485	6	
	ESS-10240		RS485	6	
	ESS-BOX2		RS485	6	
	ESS-BOX3		RS485	6	
	ESS-BOX4		RS485	6	
	ES-BOX2		RS485	6	
	ES-BOX5		RS485	6	
	ES-BOX12		RS485	6	
Sunwoda	H4850M	✓	CAN	0	
	SunESS		CAN	0	
APIUM	Atrix AP-5	✓	CAN	0	
	APR-5		CAN	0	

Brand	Model	48V Storage Inverter	RS485 or CAN	Inverter Setup	Notes
VISION Group	V-LFP51.2V100Ah-5KW	✓	CAN	13	
	VLFP51.2V200Ah-5KW		CAN	13	
Alpha Ess	M4856-P	✓	CAN	0	
	SMILE BAT		CAN	0	
BYD	BYD Battery-Box LV Flex Lite	✓	CAN	0	
Greenrich	AU5500(UP3686)	✓	CAN	0	
	AU7500(UP5000)			0	
	AU9000(UP6100)			0	
	AW7500(WM5000)			0	
	SSRE-EU10K			0	
TOPBAND	TB51100F-T110	✓	CAN	0	
	TB51120-T110		CAN	0	
Weco	4K4 LV	✓	CAN	0	
	5K3 LV		CAN	0	
GSL ENERGY	GSL051100A-B-GBP2	✓	CAN	0	
	GSL051200A-B-GBP2		CAN	0	
	GSL051280A-B-GBP2		CAN	0	
	ZnP48100ESA1		CAN	0	
	GSL-51-100		CAN	0	
	GSL-51-200		CAN	0	
DOWELL	IPACK C3.3	✓	CAN	0	
	IPACK C6.5		CAN	0	
	IPACK C10		CAN	0	
Giter	G2500-48V	✓	CAN	0	
	G5040-48V		CAN	0	
CF Energy	CFE2400	✓	CAN	0	
	CFE5100		CAN	0	
	CFE5100S		CAN	0	
Deye	SUNB-5.0-G01-48-PC SE-G5.1 PRO/AI-W5.1/ RW-M6.1	✓	CAN	0	
AOBOET	Uhome-LFP 5000	✓	CAN	0	
	Uhome-LFP 2400		CAN	0	
Wattsonic	Li-LV battery series	✓	RS485	14	
KODAK	FL5.2	✓	CAN	0	
Fox ess	LD-48100P	✓	RS485	1	
PYTES Energy	E-BOX 48100R	✓	CAN	0	
BST	MD48-100	✓	CAN	0	
	MD48-50		CAN	0	
Rosen Solar Energy	LFP48V200AH	✓	CAN	0	
	LFP51.2V200AH		CAN	0	

Brand	Model	48V Storage Inverter	RS485 or CAN	Inverter Setup	Notes
Highstart	HSD4870	✓	CAN	0	
BALANCELL	P26	✓	CAN	0	
	P27		CAN	0	
Photon	PTN-BAT-05K-WM-LFP (5KWh / 100Ah)	✓	CAN	0	CANH = Pin 4 CANL = Pin 5
ZRGP	ZR-FC48100-1630J1	✓	CAN	0	
	ZR-FS4850-160S1		CAN	0	
	ZR-FS48100-160S1		CAN	0	
	ZR-PBX1		CAN	0	
UFO	U-P48200-7	✓	CAN	0	
	U-P48100-7		CAN	0	
	U-P48150-1		CAN	0	
DMEGC	L01-48100	✓	CAN	0	
	L02-48200		CAN	0	
Robuste	LR48100	✓	CAN	0	
	LR48200		CAN	0	
Soluna	4K Pack	✓	CAN	0	
	5K Pack		CAN	0	
	EOS-5K Pack		CAN	0	
REVOV	R100	✓	CAN	0	
PAND	Powerfree Rack	✓	CAN	0	
	Powerfree Cube	✓	CAN	0	
CLiS (Zhongneng Lithium Battery Technology Taizhou Co., Ltd.)	Enerhi-M Series	✓	CAN	0	
LBSA	LBSA 51.2V/100Ah	✓	CAN	0	
Freedomwon	Freedomwon Lite Commercial 52V and LV Models	✓	CAN	0	
GSO	GBP48	✓	CAN	0	
Sunketess	LFP5000	✓	CAN	0	
Vestwoods	VT Series	✓	CAN	0	
	VE Series		CAN	0	
Green Solutions Inc.	HOME E10	✓	CAN	0	
nRuiT Energy	PowerPorter 5.0/9.0/10.0/12.0/15.0	✓	CAN	0	
Far East Battery	FEB LV Series	✓	CAN	0	
	Gen2 P48200-7		CAN	0	
GEN2	Gen2 P48100-7	✓	CAN	0	
	Gen2 P48150-1		CAN	0	

Brand	Model	48V Storage Inverter	RS485 or CAN	Inverter Setup	Notes
LEMAX	LM-JW-51.2V100Ah	✓	CAN	0	
	LM-JW-51.2V200Ah		CAN	0	
COOLI	CLR5KWH	✓	CAN	0	
	CLW5KWH		CAN	0	
	CLR10KWH		CAN	0	
	CLW10KWH		CAN	0	
	CLH10KWH		CAN	0	
	ESS10240		CAN	0	
VOLTA	VOLTA STAGE1	✓	CAN	0	
	VOLTA STAGE2		CAN	0	
	VOLTA STAGE3		CAN	0	
	VOLTA STAGE4		CAN	0	
EVO	EVO 5.7KWH 48V-120Ah	✓	CAN	0	
Yoshopo	BB-LFP-100Ah-P	✓	CAN	0	
BNP	51.2V 100Ah	✓	CAN	0	
Shanghai Green Tech Co.,Ltd.	GTEM-48V2500	✓	RS485	12	
Unipower	UPI.FP4845	✓	RS485	15	
LD	LD-100P210J	✓	RS485	17	
Felicity	LPBF Series	✓	RS485	12	
	LPBA-OL Series		RS485	12	
	LPBA-IL Series		RS485	12	
BSL	B-LFP51.2V 100Ah	✓	CAN	0	Float voltage 54.5V Absorption V 55.00V Disable equalisation 0 Days Shutdown 20% Low Batt 35% Restart 50%
	B-FLP51.2V 125Ah				
	B-LFP48-130E 51.2V 130Ah				
	B-LFP48-160E 51.2V 160Ah				
	B-LFP51.2V 200Ah Powerwall				
Enersol Lithium	48-100	✓	CAN	0	BMS cable – straight RJ45 cable (no need to change pin outs on cable) Dip Switch settings is 1000 (for single battery)
	51-100		CAN	0	
	51-200		CAN	0	
	51-100WM		CAN	0	
	51-200WM		CAN	0	
Blue Nova Rackpower	RacPower BN52-100-5.2K BP	✓	CAN	0	CANH = Pin 4 CANL = Pin 5
	RacPower BN52-100-5.2K DU		CAN	0	

Brand	Model	48V Storage Inverter	RS485 or CAN	Inverter Setup	Notes
Blue Nova HC	BN52V-280-14.5K HC	✓	CAN	0	Can be used with or without BMAC
	BN52V-560-29K HC		CAN	0	https://www.blunova.co.za/wp-content/uploads/2015/11/BN-UserManual-HC_v102.pdf
	BN52V-840-43.6K HC		CAN	0	
	BN52V-1120-58.2K HC		CAN	0	CANH = Pin 7
	BN52V-1400-72.8K HC		CAN	0	CANL = Pin 8
Blue Nova Rack Series	BN52V-840-43.6K BR	✓	CAN	0	BlueNova-BMAC-Manual-v4.pdf
	BN52V-1120-58.2K BR		CAN	0	



NOTICE

If the inverter does not communicate with the battery, do not overcharge the battery bank. Many lithium batteries have a current limit of 100A. Some are rated lower, and others higher. Always follow the voltage and current ratings provided by the battery manufacturer.

If you are using lead-acid batteries, use the following guideline:

- Maximum charge or discharge current = Battery Ah × 0.25
- Example: A 200Ah battery array composed of 4 x 200Ah batteries in series has a maximum discharge of only 50Ah (200 × 0.25 = 50)

Also, make sure:

- The cable size is suitable for the required current.
- The fuses are rated correctly according to the battery manufacturer's recommendation.

Grid Setup

The Grid Setup page allows users to configure grid-related parameters, including connection type, protection settings, and advanced reactive power features.

Access this page by tapping the "Grid Setup" icon under the Settings menu.

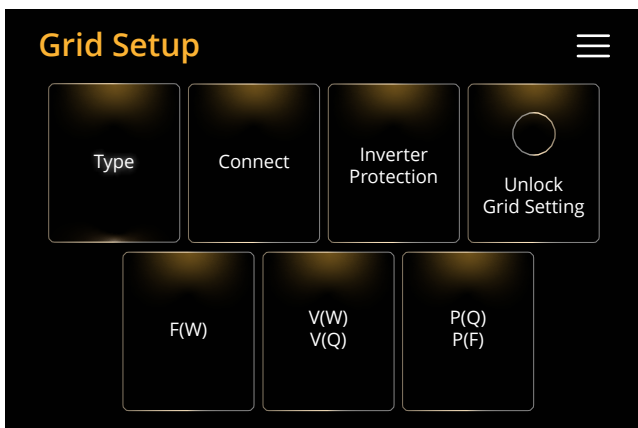

What you can do from this page:

- Set up the Grid Type functions.
- Set up the Grid Connection.
- Set up the Inverter Protection.
- Unlock Grid Settings. The inverters grid settings are automatically locked, so if you need to make changes to the grid settings you will need to select this, and it will as for password code.
- Set up the F(W), V(W), V(Q), P(Q), and P(F).

Grid | Type

The Grid Type menu allows you to configure how the inverter operates in relation to your local grid standard. You can set the grid compliance mode, frequency, grid connection type, and the inverter's output voltage.

Access this page by selecting "Type" from the Grid Setup menu.

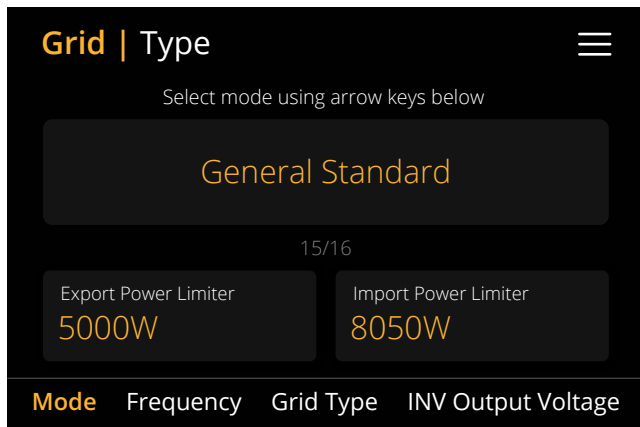

Grid Mode Selection

- Use the arrow keys to select a mode. Follow your local grid code and choose the matching grid standard from the menu, or manually input settings if unavailable. *G100: Please ensure the inverter is set to G99/G100 for compliance with local regulations.
- Export Power Limiter: Sets the maximum power allowed to flow to the grid.
- Import Power Limiter: Limits grid input power. This has a lower priority than "grid peak shaving" if both are enabled.

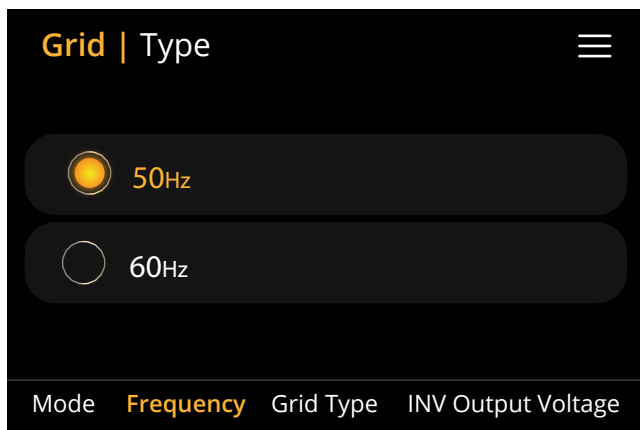

Grid Frequency

- Set the grid frequency to either 50Hz or 60Hz based on your regional standard.

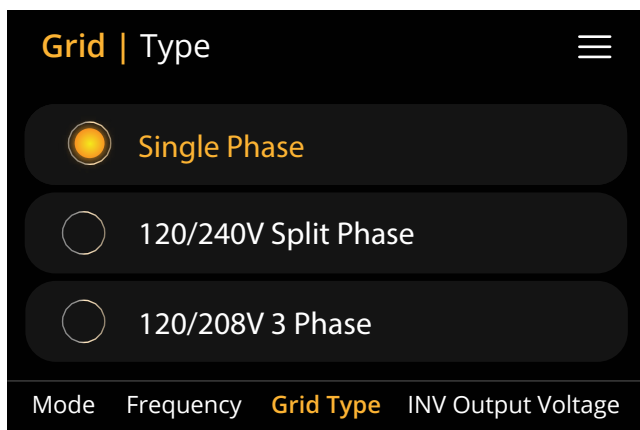

Grid Type

- Select your connection type:
 - Single Phase
 - 120/240V Split Phase
 - 120/208V 3 Phase

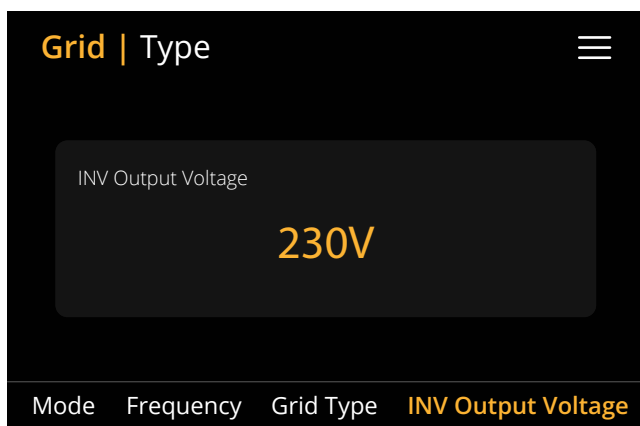

Inverter Output Voltage

- Set the inverter output voltage.
Example: 230V for standard single-phase output.

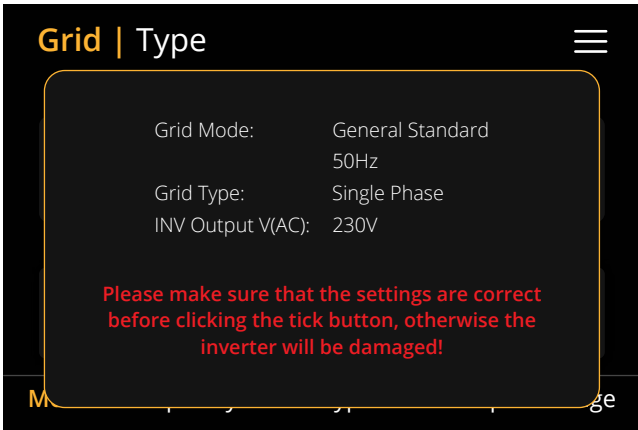

This screen is displayed after every Grid | Type tab is ticked.

Grid | Connect

The Grid Connect page allows you to configure the parameters for the inverter's connection to the grid, including the allowed voltage and frequency ranges, power ramp settings, reconnection settings, and the power factor.

Access this page by selecting "Connect" from the Grid Setup menu.

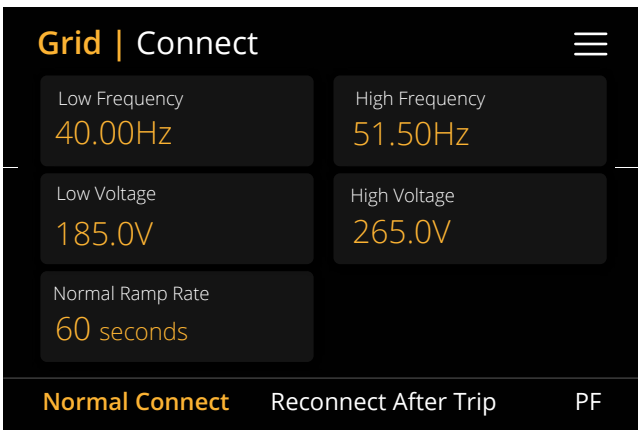

Grid Connection Settings (First Time Connect)

- Set the allowed grid voltage/frequency range for when the inverter first connects to the grid.
- Set the startup power ramp (Normal Ramp Rate) to control how quickly the inverter starts its operation.

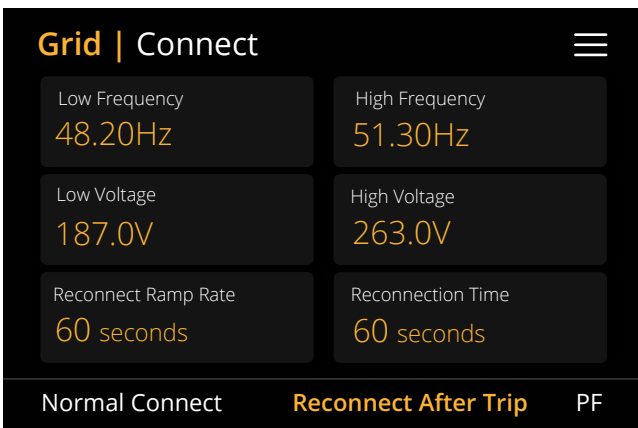

Grid Reconnection Settings (After Trip)

- Set the allowed grid voltage/frequency range for the inverter to reconnect to the grid after a trip.
- Set the reconnection power ramp (Reconnect Ramp Rate) to control the speed at which the inverter reconnects to the grid.
- Set the waiting time period (Reconnection Time) for how long the inverter will wait before attempting to reconnect to the grid.

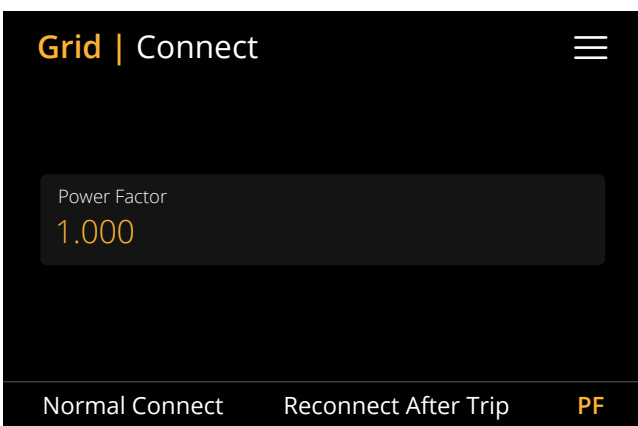

Power Factor Setting

- Set the Power Factor, which adjusts the inverter's reactive power for efficient grid operation.



If G98/G99 is selected under Grid | Type, clicking "Connect" will display the screen shown on the left.

Grid | Inverter Protection

The Inverter Protection page allows you to set the voltage and frequency protection points for the inverter. This helps ensure that the inverter shuts down or disconnects if the grid's parameters fall outside acceptable ranges, protecting both the inverter and connected components.

Access this page by selecting "Inverter Protection" from the Grid Setup menu.

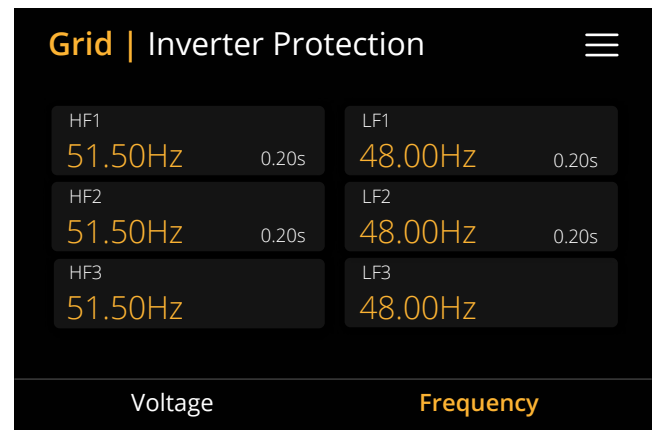
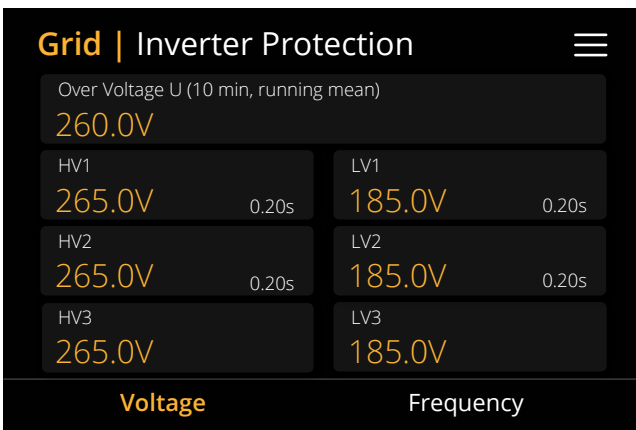

Voltage Protection Settings

- HV1 (Over Voltage Protection Level 1): Set the level 1 overvoltage protection point. It triggers when the grid voltage exceeds the defined value.
- HV2 (Over Voltage Protection Level 2): Set the level 2 overvoltage protection point.
- HV3 (Over Voltage Protection Level 3): Set the level 3 overvoltage protection point.
- LV1 (Under Voltage Protection Level 1): Set the level 1 undervoltage protection point. The inverter disconnects if the grid voltage falls below this level.
- LV2 (Under Voltage Protection Level 2): Set the level 2 undervoltage protection point.
- LV3 (Under Voltage Protection Level 3): Set the level 3 undervoltage protection point.
- 0.20s: Set the trip time, which determines how long the inverter waits before disconnecting after a protection trip event occurs.

Frequency Protection Settings:

- HF1 (Over Frequency Protection Level 1): Set the level 1 over frequency protection point. This setting will disconnect the inverter if the grid frequency exceeds the threshold.
- HF2 (Over Frequency Protection Level 2): Set the level 2 over frequency protection point.
- HF3 (Over Frequency Protection Level 3): Set the level 3 over frequency protection point.
- LF1 (Under Frequency Protection Level 1): Set the level 1 under frequency protection point.
- LF2 (Under Frequency Protection Level 2): Set the level 2 under frequency protection point.
- LF3 (Under Frequency Protection Level 3): Set the level 3 under frequency protection point.

Grid | F(W)

The F(W) page allows you to configure the inverter's active power output based on the grid frequency. You can adjust the parameters related to the start frequency, stop frequency, and the droop value to ensure that the inverter operates according to the grid frequency requirements.

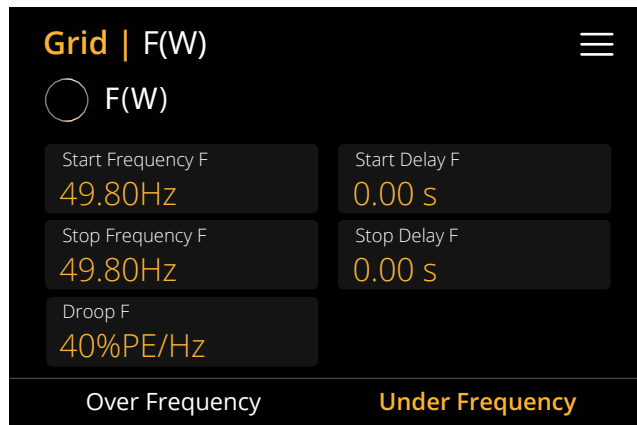
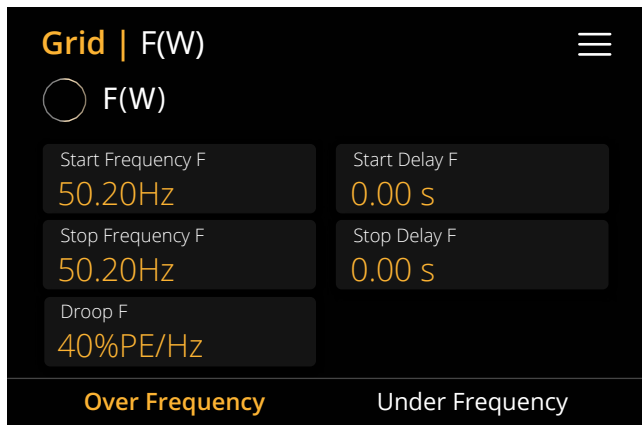

What you can do from this page:

- FW: This setting allows the inverter to adjust its active output power in response to variations in the grid frequency.
- Droop f: This value determines the percentage of nominal power that will be reduced per Hz of frequency change. For example, a droop value of 40% means that for every 1Hz change in the grid frequency, the inverter's output will decrease by 40% of its nominal power.
- Start Delay f and Stop Delay f: These settings control the time delay before the inverter begins adjusting power in response to grid frequency changes. For example, a Start Delay f of 0.00s means that the inverter will react instantly as soon as the grid frequency hits the defined threshold (e.g., 50.20Hz or 49.80Hz).

Over Frequency Example:

- Start Frequency f: 50.20Hz → This means that once the grid frequency reaches 50.20Hz, the inverter will begin to decrease its output power.
- Stop Frequency f: 50.20Hz → Once the grid frequency drops below 50.20Hz, the inverter will stop decreasing its power.
- Droop f: 40%PE/Hz → For every 1Hz drop in the grid frequency, the inverter will decrease its output power by 40% of its nominal capacity (PE stands for nominal power output).
 - For example, if the frequency drops to 50Hz, the inverter reduces its output by 40% of its rated capacity.

Under Frequency Example:

- Start Frequency f = 49.80Hz → The inverter will begin to reduce its output once the grid frequency drops below 49.80Hz.
- Stop Frequency f = 49.80Hz → Once the grid frequency falls below 49.80Hz, the inverter will continue to adjust its output power accordingly.
- Droop f: 40%PE/Hz → For each 1Hz drop in grid frequency below 49.80Hz, the inverter will reduce its output by 40% of its nominal power.
 - For instance, if the grid frequency drops to 49.50Hz, the inverter will cut back its output by 40% of its rated power in response to the grid's under-frequency condition.

Grid | V(W) V(Q)

This page allows users to configure how the inverter adjusts its active and reactive power based on grid voltage. These settings help the inverter adapt its output to meet grid stability requirements.

V1	P1
109.0%Un	100%
V2	P2
110.0%Un	20%
V3	P3
111.0%Un	20%
V4	P4
111.0%Un	20%

Lock-in/Pn	V1	V2
20%	94.0%Un	97.0%Un
	V3	V4
	105.0%Un	108.0%Un
Lock-out/Pn	Q1	Q2
5%	43.6%	0.0%
	Q3	Q4
	0.0%	-43.6%

What you can do from this page:

- V(W): This setting adjusts the inverter's active power according to the grid voltage. It ensures that the inverter's output is correctly scaled depending on the grid voltage level.
- V(Q): This setting adjusts the reactive power of the inverter. The reactive power is crucial for maintaining voltage stability in the grid. It responds to fluctuations in the grid voltage, adjusting both active and reactive power as needed.
- Lock-in/Pn 20%: This setting locks the VQ mode (reactive power control) when the inverter's active power is less than 20% of its rated capacity. This prevents unnecessary power adjustments if the inverter is operating at very low output levels.
- Lock-out/Pn 5%: This setting activates VQ mode when the inverter's active power reaches between 5% and 20% of its rated capacity. This ensures that reactive power control starts taking effect as the inverter's output increases.

V(W) Examples:

- V1 = 109.0% Un, P1 = 100% → This means that when the grid voltage reaches 109% of the nominal voltage, the inverter will output 100% of its rated active power.
- V2 = 110.0% Un, P2 = 20% → If the grid voltage increases to 110% of the rated voltage, the inverter will reduce its active output power to 20% of the rated power. This helps protect the inverter and the grid from overvoltage conditions.
- V3 = 111.0% Un, P3 = 20% → At 111% of the grid voltage, the inverter again limits the active output to 20% of the rated power, which prevents excessive power generation in overvoltage scenarios.

V(Q) Examples:

- V1 = 94.0% Un, Q1 = 43.6% → This means that when the grid voltage drops to 94% of the rated voltage, the inverter adjusts its reactive output to 43.6% of the rated capacity, maintaining grid voltage stability.
- V2 = 97.0% Un, Q2 = 0.0% → At 97% of the rated grid voltage, the inverter reduces its reactive power output to 0.0%, ensuring minimal impact on grid voltage stability.
- V3 = 105.0% Un, Q3 = 0.0% → When the grid voltage reaches 105% of the rated voltage, the inverter keeps its reactive power output at 0.0%, effectively reducing the impact of high voltage on the grid.
- V4 = 108.0% Un, Q4 = -43.6% → At 108% of the rated grid voltage, the inverter outputs -43.6% of reactive power (i.e., it absorbs reactive power from the grid), which helps bring down the grid voltage in an overvoltage situation.

For the detailed setup values, please follow the local grid code.

Grid | P(Q) P(F)

This page allows users to configure how the inverter adjusts reactive power (Q) and power factor (PF) based on its active power output. These settings help the inverter respond correctly to changes in system load or grid voltage, as required by local grid codes.

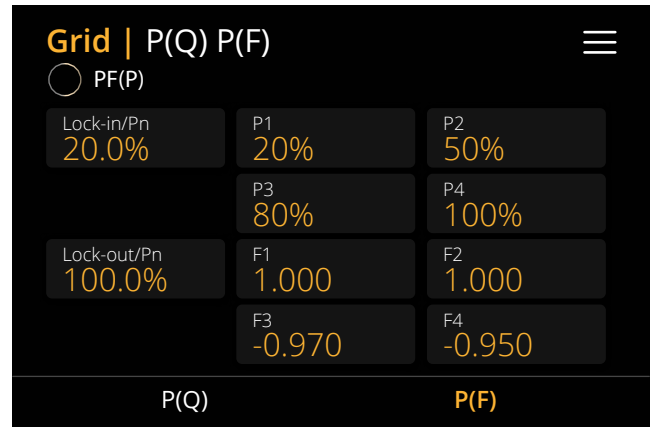

What you can do from this page:

- P(Q): Adjusts the inverter's reactive power (Q) according to its current active power (P). The inverter will deliver or absorb reactive power based on the programmed set points.
- P(F): Adjusts the Power Factor (PF) dynamically, based on the inverter's active power output.
- Lock-in/Pn 20%: Sets the minimum percentage of rated active power at which the P(F) mode becomes active. If output is below this value, P(F) mode will not take effect.
- Lock-out/Pn 100%: If the inverter's active power exceeds this value, the P(F) mode will stop functioning.
- For the detailed setup values, please follow the local grid code.

P(Q) Example: When the inverter outputs 20% to 100% active power, it consistently delivers 20% reactive power (Q), maintaining grid support within that range.

P(F) Example: This configuration allows the inverter to operate at unity power factor (PF = 1.000) up to 50% load, then gradually shift to a leading (capacitive) power factor as load increases. This supports voltage control in high load scenarios.



NOTICE

Only when the grid voltage is equal to or higher than 1.05 times the rated grid voltage will the P(F) mode take effect.

System Mode

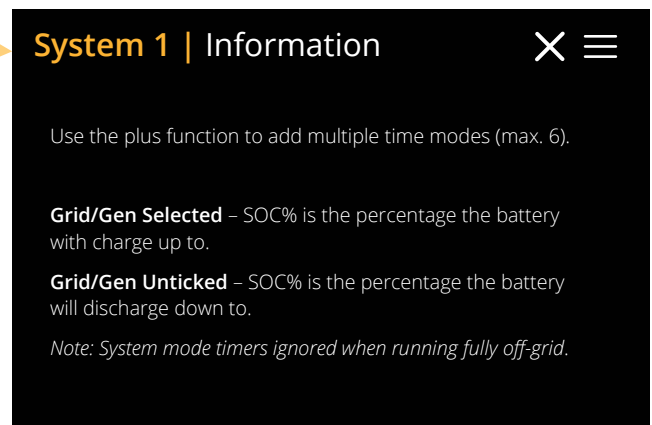
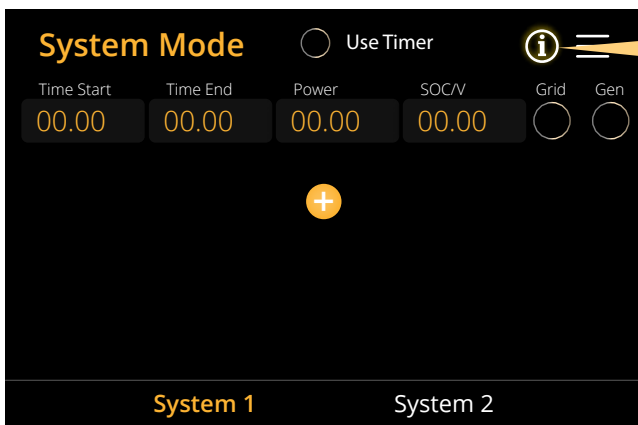

System Mode				<input type="radio"/> Use Timer		
Time Start	Time End	Power	SOC/V	Grid	Gen	
00.00	00.00	00.00	00.00	<input checked="" type="radio"/>	<input type="radio"/>	
05.00	08.00	5000	40%	<input type="radio"/>	<input type="radio"/>	
08.00	10.00	5000	80%	<input type="radio"/>	<input type="radio"/>	
10.00	15.00	5000	40%	<input type="radio"/>	<input type="radio"/>	
15.00	18.00	5000	35%	<input type="radio"/>	<input type="radio"/>	

System 1 System 2

Example:

- From 00:00 to 05:00, if the battery SOC falls below 80%, the system charges the battery from the grid until SOC reaches 80%.
- From 05:00 to 08:00, if the battery SOC is above 40%, the system discharges the battery until SOC reaches 40%.
- From 08:00 to 10:00, when the SOC exceeds 80%, the inverter discharges the battery to bring SOC down to 80%.
- From 10:00 to 15:00, the system discharges the battery until the SOC drops to 40%.
- From 15:00 to 18:00, the system discharges the battery until SOC reaches 35%.

Gen & Aux Load

This page allows users to configure generator input, auxiliary load output, AC coupling, and micro inverter support. These settings help optimise how the system handles additional power sources or directs excess power to other loads, such as water heaters.

What you can do from this page:

- Set up a generator input.
- Set an auxiliary load output.
- Enable generator peak shaving and set the maximum output power.
- Connect the generator to the grid.
- Use an additional inverter or micro inverter.



NOTICE

When the batteries are full and the inverter is still producing power from solar or wind, you can redirect the excess energy to another load—such as a water heater.

Gen Input: Activates the generator input function. Once enabled, the system will allow power from a connected generator.

- **Gen Peak Shaving Power:** Limits the generator's output to a user-defined value (e.g. 8000W shown). If the total system load exceeds this value, the remaining power is supplied by the solar PV or battery system.
Example: If total load is 10 kW and the peak shaving is set to 8 kW, the generator provides 8 kW, and the remaining 2 kW comes from PV or battery.
- **Gen Connect to Grid:** Allows the generator to connect directly to the grid. This function should only be used if permitted by local regulations.
- **AC Couple on Grid Side (Reserved):** Currently has no active function in this firmware version.
- **AC Couple on Load Side:** Used when connecting an on-grid or micro inverter to the load port. In this case, note that the hybrid inverter may not correctly detect the power contribution from the additional inverter.

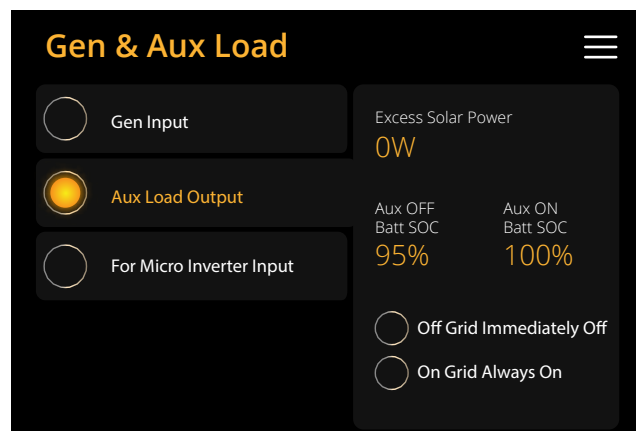

Aux Load Output: This page allows you to configure the Aux Load Output mode. In this mode, the Gen input is repurposed as an auxiliary output, supplying power to connected loads only when battery SOC and solar (PV) power exceed specific thresholds.

- Set the Aux ON Batt SOC – the battery SOC level at which the load will turn ON.
- Set the Aux OFF Batt SOC – the battery SOC level at which the load will turn OFF.
- Set the Excess Solar Power threshold – the minimum amount of available PV power required for activation.
- Choose the grid behaviour for this output:
 - Off Grid Immediately Off: The aux load will switch OFF immediately when the grid disconnects.
 - On Grid Always On: The aux load will stay ON as long as the grid is present.

Example: Aux ON Batt SOC → 100%, Aux OFF Batt SOC → 95%, Excess Solar Power → 500 W.

- The Aux Load Output will turn ON when the battery SOC reaches 100% and PV power exceeds 500 W.
- It will turn OFF automatically if the battery SOC drops below 95% or PV power falls below the 500 W threshold.

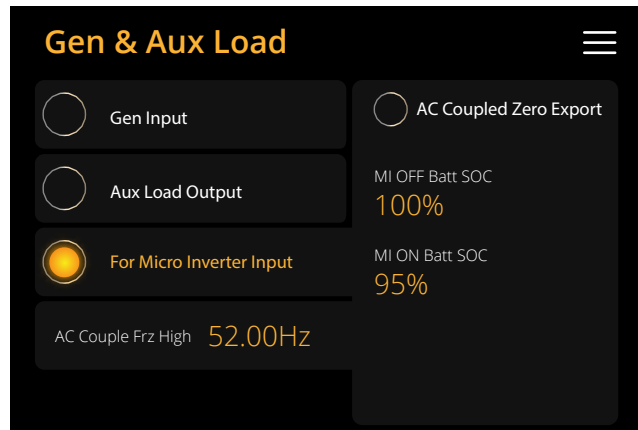

Micro Inverter Input: This setting allows you to repurpose the Generator input port to accept power from a micro inverter or grid-tied inverter (AC-coupled system). It supports supplementary inverters up to a maximum of 4 kW and helps manage energy flow without feeding excess power back to the grid.

- Set the MI ON Batt SOC – the battery SOC level at which the micro inverter begins feeding power.
- Set the MI OFF Batt SOC – the battery SOC level at which the micro inverter stops exporting power.
- Configure the AC Couple Frz High frequency limit – the point at which the micro inverter is forced to shut down based on SOC and frequency conditions.
- Enable AC Coupled Zero Export to prevent power from being exported to the grid.

Example:

- MI ON Batt SOC → 95%: The micro inverter starts outputting power when battery SOC drops below this.
- MI OFF Batt SOC → 100%: The micro inverter stops exporting power when battery SOC reaches this level.
- AC Couple Frz High → 52.00 Hz: This is the frequency at which the system will force the micro inverter to shut down.

Advance

This page gives access to advanced settings that allow configuration of multiple inverter systems, peak shaving controls, wind turbine input, and miscellaneous system behaviours.



What you can do from this page:

- Set up Multi-Inverter: Configure parallel operation or communication with other Sunsynk inverters.
- Set up Others: Adjust additional inverter features related to external meters, switching behaviour, and solar panel efficiency. These options help fine-tune system performance, noise reduction, and grid integration.
- Set up P-Shave (Peak Shaving): Activate and configure peak shaving to limit power drawn from the grid during high load periods.
- Set up Wind Turbine: Enable and manage wind turbine input as a charging source. Includes wind mode settings and input voltage configuration.

Advance | Multi-Inverter

This screen allows you to configure multiple Sunsynk inverters to work together in parallel. Use this page when installing a system with more than one inverter connected on the same AC bus.

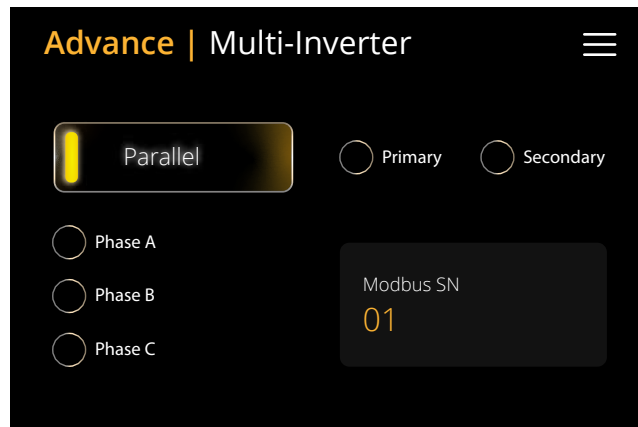

What you can do from this page:

- Enable Parallel Mode: Switch ON the parallel function so the inverter can work with others in the system.
- Primary or Secondary Role: Select whether this inverter acts as a Primary or Secondary device on the communication bus.
- Phase Selection: Choose the correct phase (A, B, or C) that this inverter is connected to in the three-phase system.
- Set Modbus SN: Assign a unique Modbus Serial Number to this inverter for communication. Each inverter in the parallel system must have a different number.

The Sunsynk Parity Inverter can operate as a standalone unit or in a parallel configuration to increase power capacity. You can set up a parallel system in single-phase or three-phase mode, depending on your installation needs.

PARALLEL SYSTEM LIMITS

- Single-phase grid: Up to 16 inverters in total (1 Master + 15 Slaves).
- Three-phase grid: Up to 15 inverters, with 5 inverters per phase (1 Master + 4 Slaves per phase). Example:
 - Phase A: Master A and 4 Slaves A
 - Phase B: Master B and 4 Slaves B
 - Phase C: Master C and 4 Slaves C

This setup delivers a balanced 3-phase output with clockwise phase rotation, suitable for both single-phase (220V L-N) and three-phase (380V L-L) loads.

INSTALLATION GUIDELINES

- Battery bank: All batteries must be connected in parallel.
- Cabling: Use a minimum 50mm² cable with fuse isolators per inverter.
- Protection: Each inverter requires:
 - Surge-protected fuse isolator.
 - RCD for each group of inverters.
 - Changeover switch (if powering main loads during outages).
- CT coils: Only connect to the Master inverter.
 - Example: For 6 inverters in 3-phase mode, 3 CT coils (one per Master) are needed.

- Communication: Use RJ45 cables to connect the inverters.
 - Cables are bidirectional (no IN/OUT).
 - Max length between units: 2 metres.
 - Each inverter must have a unique Modbus SN.
 - One master per phase only.



NOTICE

- Ensure all inverters have the same firmware version before configuring.
- Isolate each inverter's load output with individual load breakers before connecting them to the common parallel breaker.
- Only enable breakers after all units are programmed and tested.
- For three-phase systems, verify phase rotation is clockwise before powering on.
- BMS Cable Orientation: Do not swap cable ends. One end is for the inverter, the other for the BMS. Incorrect installation may cause communication errors on screen.

TROUBLESHOOTING & FAQs

Q1: What is the sequence to install/connect/commission?

First of all, leave the main supplies off. Next, connect all communication cables, set up all LCDs and then, last of all, turn on the main supplies.

Q2: What are the indications that the communication and the system are OK or not?

Parallel errors will be shown as fault F46 on the display.

Q3: What are the consequences of not setting one inverter in a parallel mode?

It can damage the inverter.

Q4: What are the consequences of having more than one Master Inverter or having no inverter set as 'Master'?

It can damage the inverter. There are cases in which it is possible to have more than one master. For example, as aforementioned, six inverters paralleled in a three phase utility grid (three masters).

Q5: What are the consequences for setting A, B, or C phases wrong while in parallel mode?

It can damage the inverter. Recommend checking the phase rotation with a meter before switching on.

Q6: What are the consequences of factory resetting, power cycling, or firmware updating one inverter in a parallel system?

It can damage the inverter. Inverters needs to be isolated from each other before factory reset or firmware update.

Q7: What consequences for changing ALL/ANY settings while operating in parallel mode?

It can damage the inverter and fault F46 will be indicated on the display.

For support and resources (including training videos), visit: www.sunsynk.com

Advance | Others

This page allows users to configure auxiliary settings such as external meters, noise reduction mode, and PV tracking optimisation.

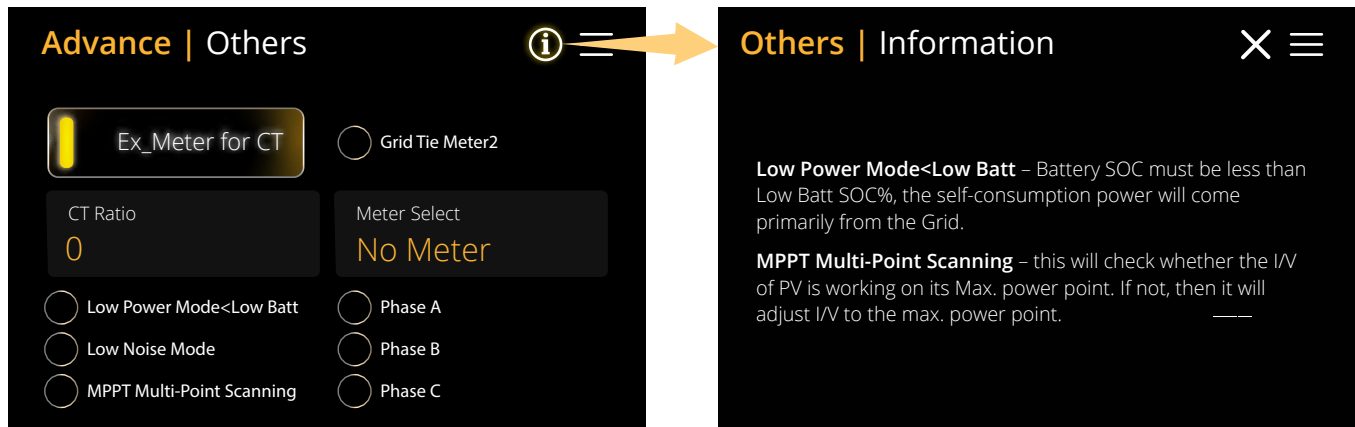

What you can do from this page:

- Ex_Meter for CT: Select this when using a CHINT DTSU666 three-phase energy meter. Choose the correct phase where the inverter is connected:
 - If connected to Phase A, select Phase A.
 - If connected to Phase B or C, select accordingly.
- CT Ratio: Set the current transformer (CT) ratio according to your meter specifications.
- Meter Select: Choose the type of external meter installed in the system. This ensures proper communication between the inverter and the meter.
- Low Power Mode < Low Batt: When enabled, the inverter will draw power from the grid if the battery's State of Charge (SOC) drops below the configured threshold. This helps avoid deep battery discharge during low capacity periods.
- Low Noise Mode: Adjusts the IGBT switching frequency from 15kHz to 20kHz to reduce audible noise. Use this mode to eliminate high-pitched sounds that some users may hear from the inverter or nearby electrical equipment.
- Grid Tie Meter 2: When a string inverter is AC-coupled to the grid or to the load side of the hybrid inverter, select this option. The Sunsynk inverter LCD will show the PV output from the string inverter under its PV icon. Ensure the external meter is correctly communicating with the hybrid inverter.
- MPPT Multi-Point Scanning: Enables the inverter to scan and adjust to the maximum power point (I/V) of the solar array. If the inverter detects that it is not operating at the maximum point, it will re-adjust to optimise solar output.

Advance | P-Shave

The P-Shave page allows users to configure critical operational modes and protection settings that affect inverter performance under grid-tied and off-grid scenarios. These functions include arc fault detection, delayed backup, grid export limits, and regional compliance features.



What you can do from this page:

- **System Self-Check:** Activates a self-diagnostic test of the inverter system. For engineering or installer use only.
- **Signal Island Mode:** Enables off-grid functionality or islanded operation where the system runs independently from the utility grid. Recommended when using Earth-Neutral Bonding in the system.
- **DRM (Demand Response Mode):** Enables communication with the utility for grid control, as required in regions like Australia under AS4777 compliance.
- **Solar Arc Fault ON:** Activates protection against arc faults in the solar wiring. For use in U.S. models where arc fault detection is mandatory.
- **Clear Arc Fault:** Resets any detected arc fault event after inspection or fault resolution.
- **Backup Delay:** Defines the delay time before the inverter supplies backup power after grid failure.
 - Example: If set to 3 ms, the inverter will start delivering power 3 milliseconds after a grid cut-off.
- **Grid Peak Shaving:** Limits the power exported to the grid to a preset value (e.g., 8000 W). If the connected load exceeds this limit, the inverter supplements the load with PV and battery energy. If solar and battery power are insufficient, additional grid power is drawn to meet demand.
- **ATS (Automatic Transfer Switch):** Displays the current status of the ATS feature. OFF indicates ATS is not active.

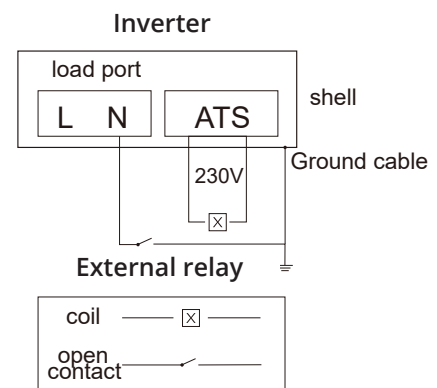

Advance | Wind Turbine

This page allows users to configure one of the inverter's MPPT (Maximum Power Point Tracking) channels to operate with a wind turbine instead of a solar PV input. The wind turbine input uses a customised voltage-to-current (V/I) curve to optimise energy capture as wind speed varies.

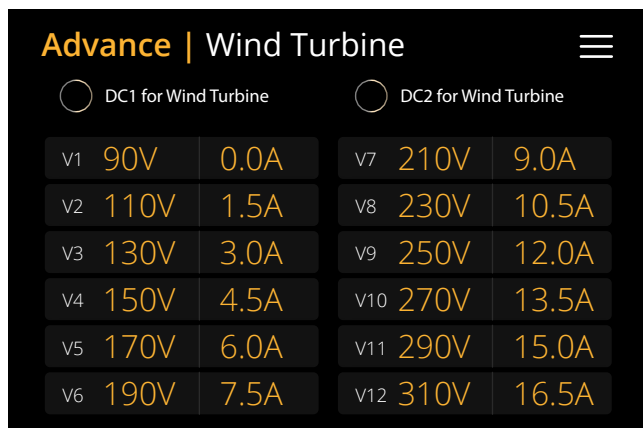

V1	90V	0.0A	V7	210V	9.0A
V2	110V	1.5A	V8	230V	10.5A
V3	130V	3.0A	V9	250V	12.0A
V4	150V	4.5A	V10	270V	13.5A
V5	170V	6.0A	V11	290V	15.0A
V6	190V	7.5A	V12	310V	16.5A

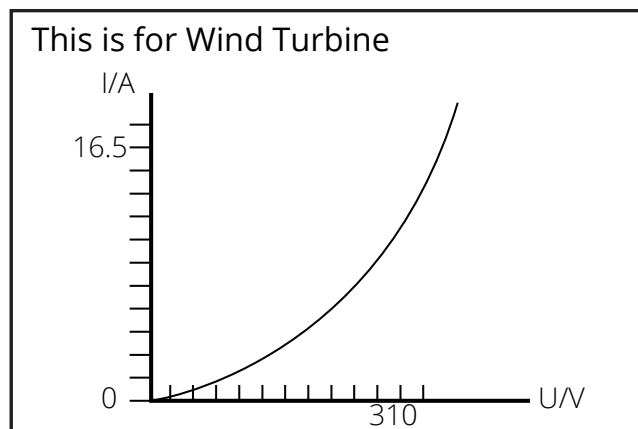

What you can do from this page:

- Select MPPT Input (DC1 or DC2): Choose whether MPPT 1 (DC1) or MPPT 2 (DC2) will be used as the Wind Turbine Input. Only one MPPT can be used for wind input.
- View Customised Curve: The V/I curve on the right represents how the inverter adjusts current draw as the wind turbine voltage increases. The rising curve ensures safe and efficient power harvesting across a wide range of wind conditions.



NOTICE

- This mode is only compatible with wind turbines that produce a DC output.
- Make sure the V/I curve is provided by the turbine manufacturer to match the turbine's output characteristics.
- Using incorrect curve values may result in poor performance or inverter faults.

Smart Settings

The Smart Settings page allows the configuration and management of Sunsynk smart accessories, including Smartlynk and Smart Tx modules. These devices enable advanced monitoring and integration features within the Sunsynk hybrid system.

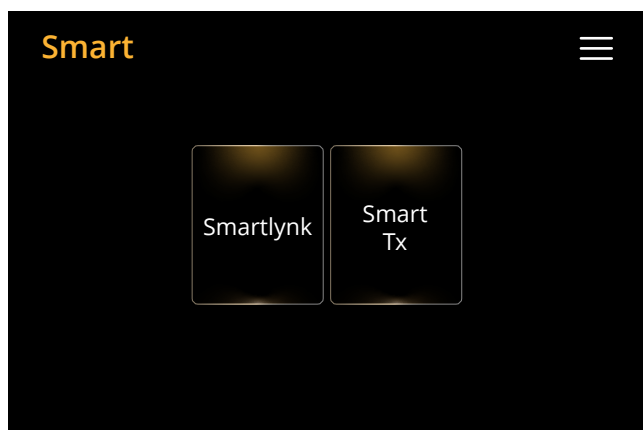

What you can do from this page:

- Smartlynk: This module is Sunsynk's communication interface for cloud-based monitoring and remote system access. When enabled, it allows real-time system data viewing, remote control, and firmware updates via the Sunsynk Connect App or web portal.
- Smart Tx (Smart Transmitter): The Smart Tx module monitors multiple current paths using CTs (Current Transformers). It's designed to measure load consumption, grid import/export, or solar generation across different points in your system.

Smart | Smartlynk

The Smartlynk page allows you to configure scheduled switching, battery-based triggers, and off-grid operation modes. It is especially useful when controlling external relays, loads, or custom energy management tasks based on time, battery State of Charge (SOC), or grid status.

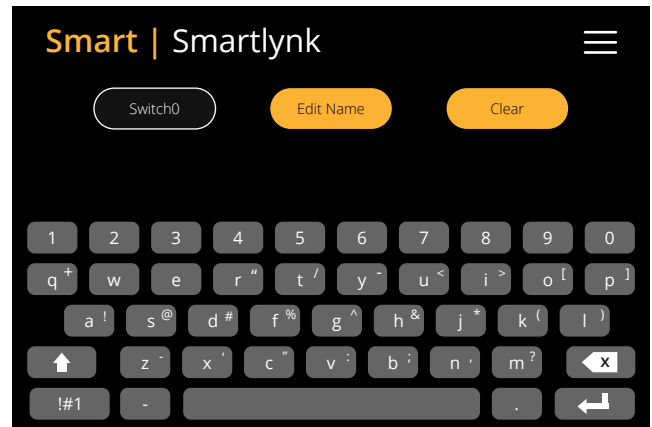
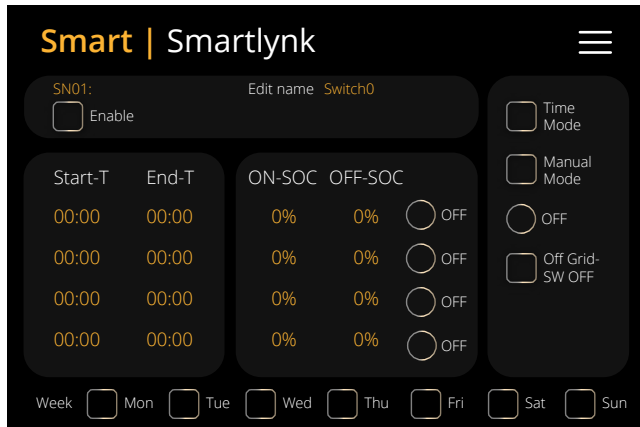

What you can do from this page:

- Enable: Activate the Smartlynk function by toggling the Enable switch.
- Edit Name: Use the Edit Name option to assign a custom label to each Smartlynk switch (e.g., Pump, Heater, Lighting). The on-screen keyboard lets you type and save a new name.
- Time Mode: Set a timer-based schedule using the Start-T and End-T fields. Select specific days of the week (Mon–Sun) for the rule to apply.
- Manual Mode: Allows you to turn the Smartlynk output ON or OFF manually, overriding any schedule or SOC trigger.
- ON-SOC / OFF-SOC: Define battery SOC thresholds to trigger the output. For example:
 - ON-SOC = 80%, OFF-SOC = 40% → The output will activate when the battery reaches 80% and deactivate when it drops to 40%.
- Off-Grid Switch (SW OFF): This option turns off the Smartlynk output when the inverter is running in off-grid mode.

Example Use Case:

You want to power a water pump only when the battery SOC is above 70% and turn it off when SOC drops below 40%, but only between 10:00 and 14:00 on weekdays.

- Set ON-SOC to 70% and OFF-SOC to 40%.
- Configure Start-T to 10:00 and End-T to 14:00.
- Enable Time Mode and select Mon to Fri.



NOTICE

Ensure the Smart CT is installed in the correct orientation and on the correct cable (live only, not neutral). CT cables must be securely connected to the Smart Tx module. If using multiple channels, verify each one is configured correctly in the system setup.

Smart | Smart TX

The Smart Tx (Smart Transmitter) menu allows users to manage the communication with a connected Smart Tx device. This module can be used in systems where additional current measurement channels are required, such as for monitoring multiple load circuits.

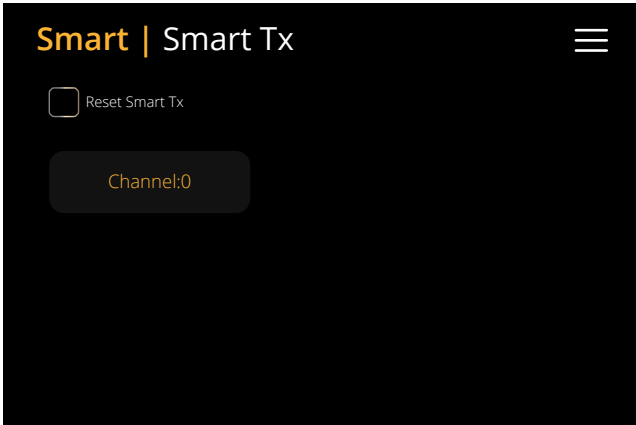

What you can do from this page:

- **Reset Smart Tx:** This option resets the communication between the inverter and the Smart Tx module. Use this if the device is not responding or needs to be reinitialised.
- **Select Channel:** Tap the Channel field to access available input channels on the Smart Tx module. Each channel typically corresponds to a CT (Current Transformer) connected to the Smart Tx unit, but configuration options may vary by firmware or system integration.

Usage Example:

If your system includes multiple load areas (e.g., main house, garage, office), Smart Tx allows you to assign a CT to each and monitor the energy usage of each zone separately.

This also supports applications like:

- Grid-tied systems where export limitation is enforced.
- Multi-load tracking for billing, optimisation, or compliance.
- Detailed diagnostics on energy flows between PV, grid, and load.

Smart CT

The Smart CT page allows users to enable and manage external Smart CT sensors for advanced current monitoring. These sensors are typically installed at different measurement points—such as grid import/export, PV production, or specific loads—to provide granular energy flow data.

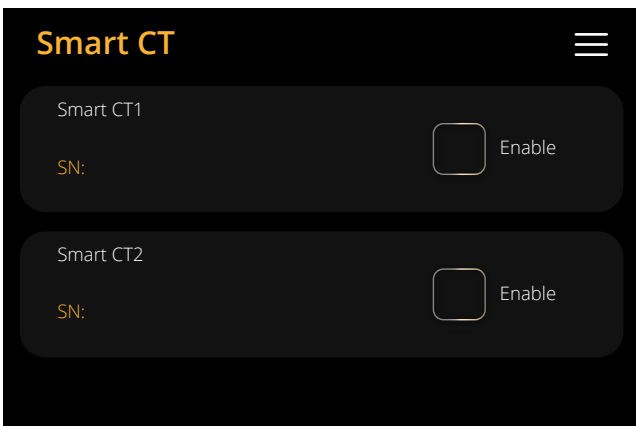

What you can do from this page:

- **Enable Smart CT1:** Activates the first Smart CT sensor. Once enabled, the system will begin reading current values from this sensor. You must enter the corresponding serial number (SN) to link the physical CT device to the inverter.
- **Enable Smart CT2:** Activates the second Smart CT sensor. This operates independently from CT1 and allows monitoring of an additional current path. As with CT1, enter the serial number (SN) shown on the sensor to ensure proper connection and data logging.



NOTICE

Ensure the Smart CTs are securely clamped around the relevant conductor and facing in the correct direction (indicated by the arrow on the sensor body).

The CTs must be correctly installed and their serial numbers registered in the system for accurate real-time measurements.

OPERATING MODES

Mode I: Basic

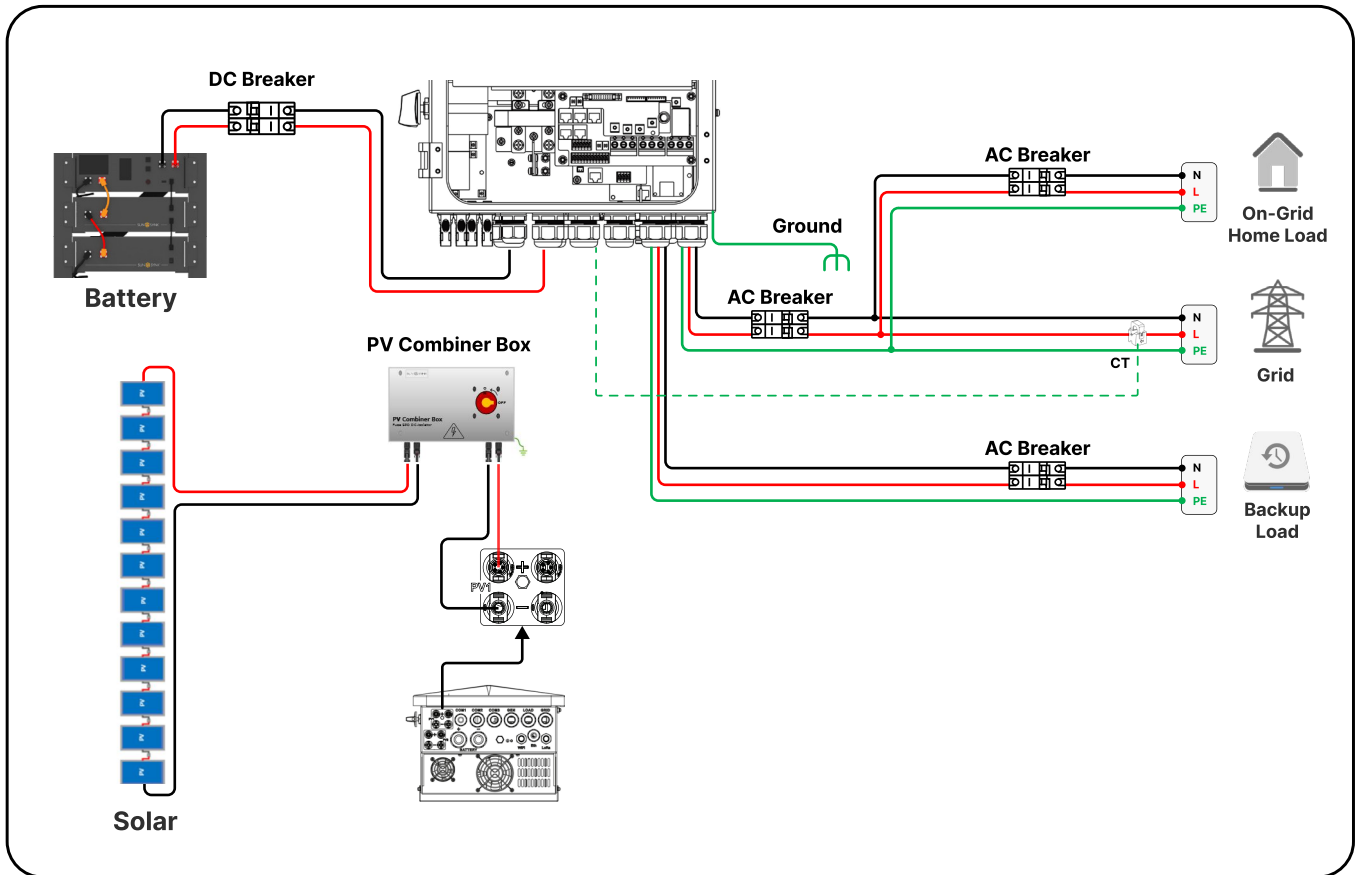

Mode II: With Generator

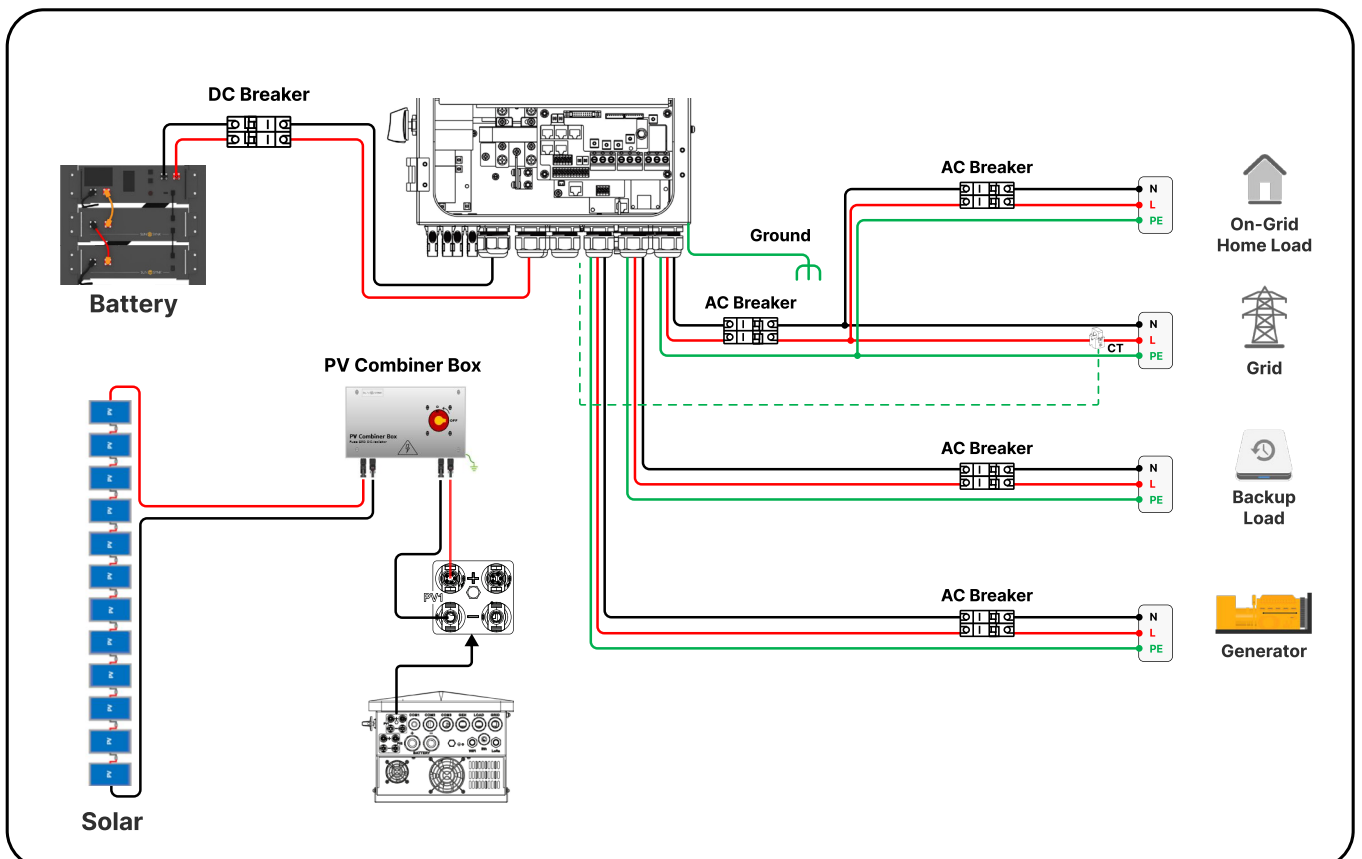

Mode III: With Aux Load

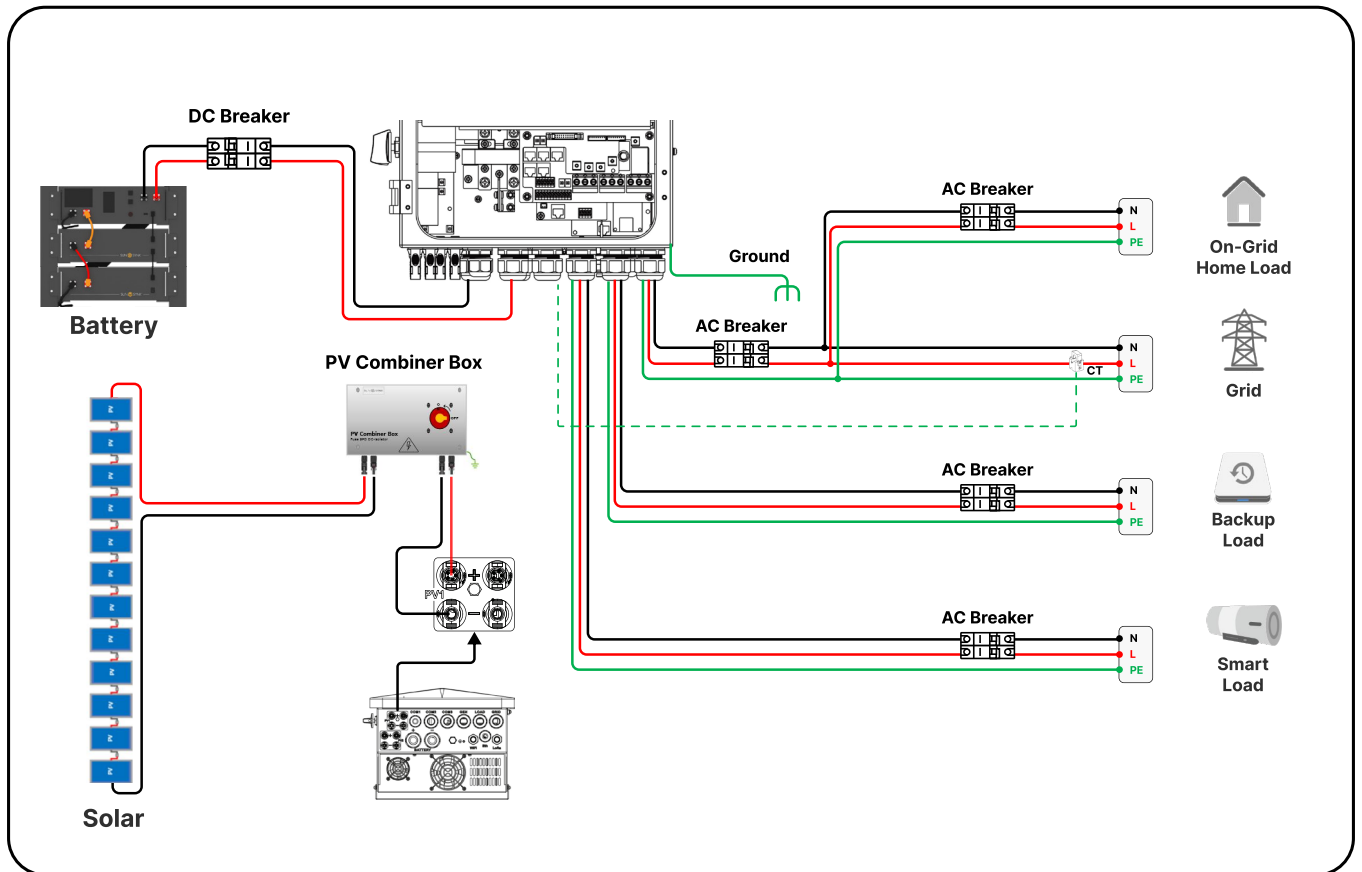

Mode IV: AC Couple

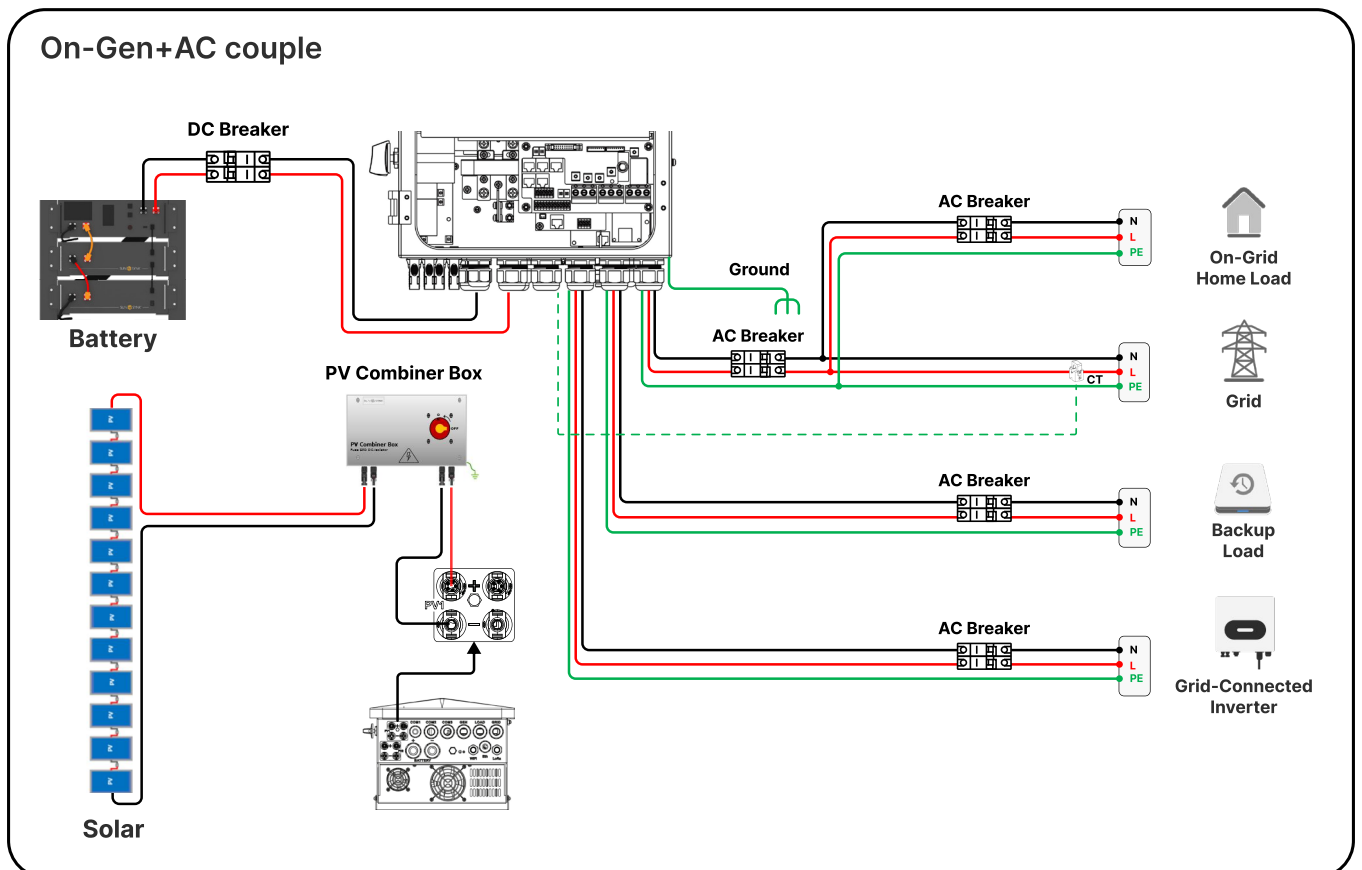

On-Grid+AC couple

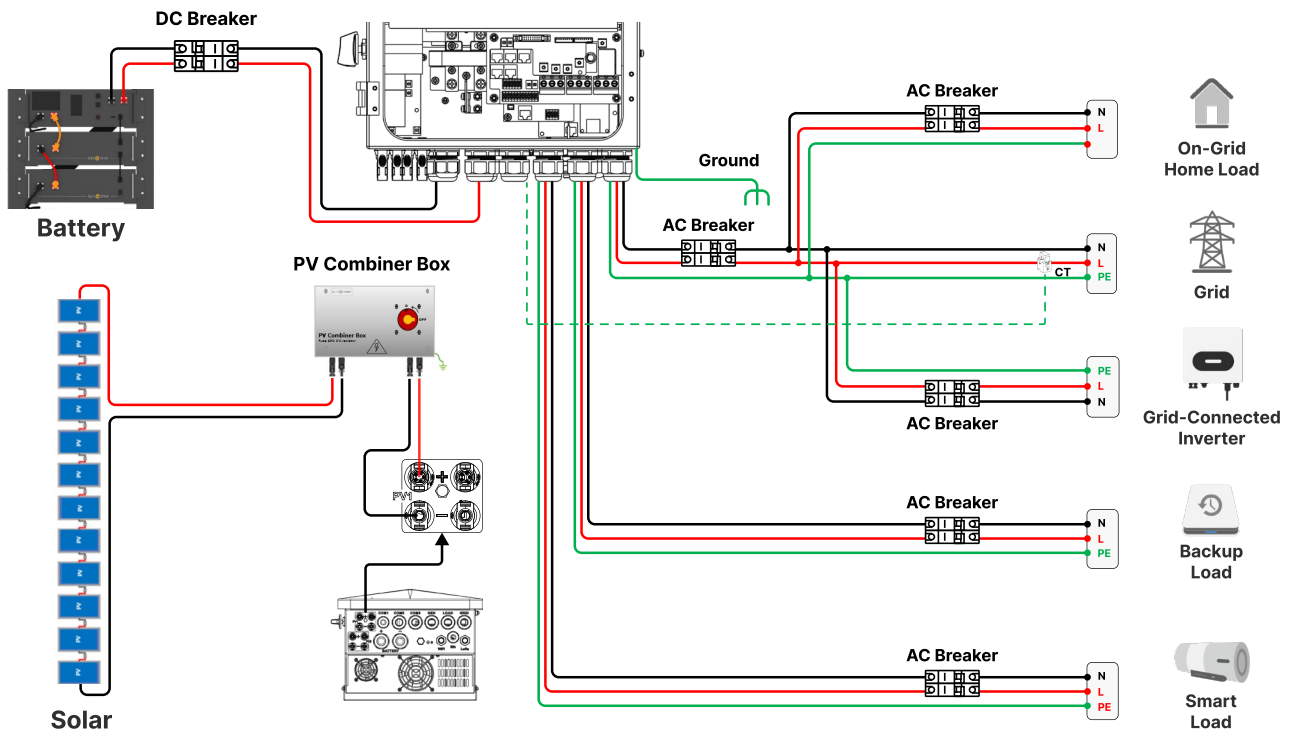

On-Load+AC couple

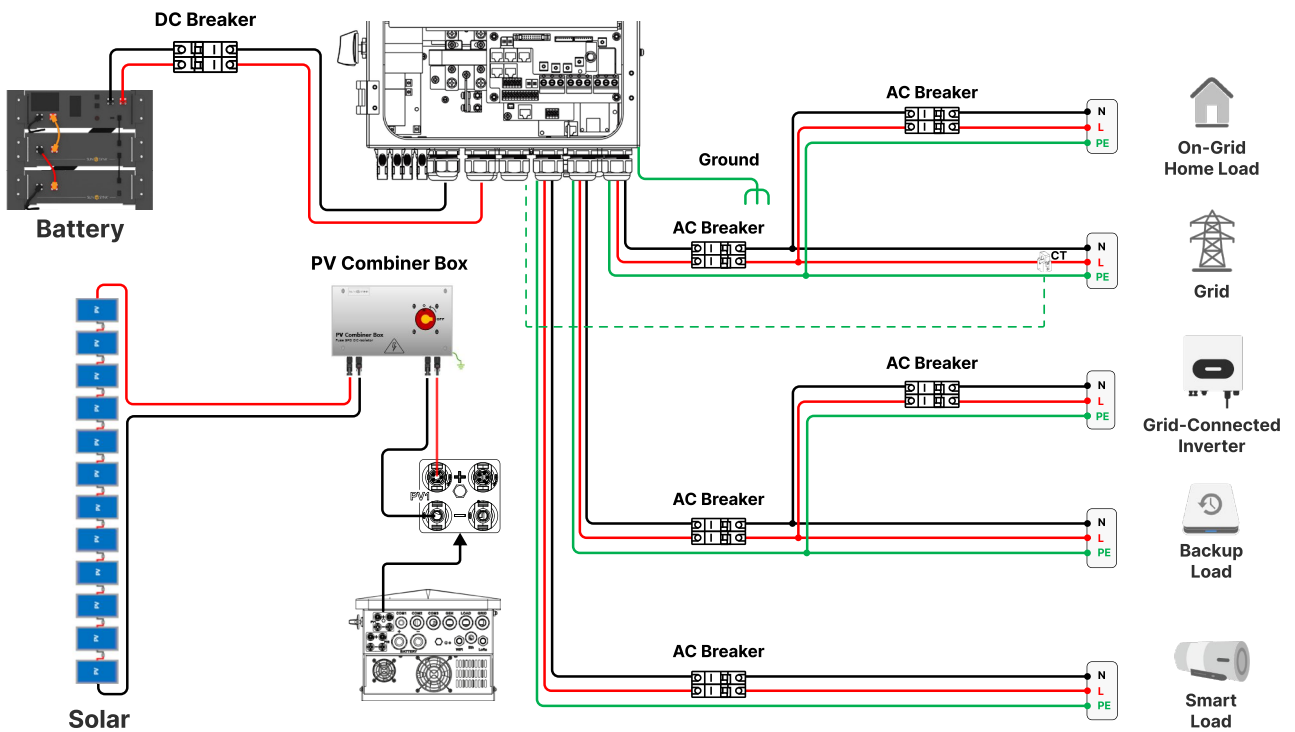

Mode V: Grid-Tied

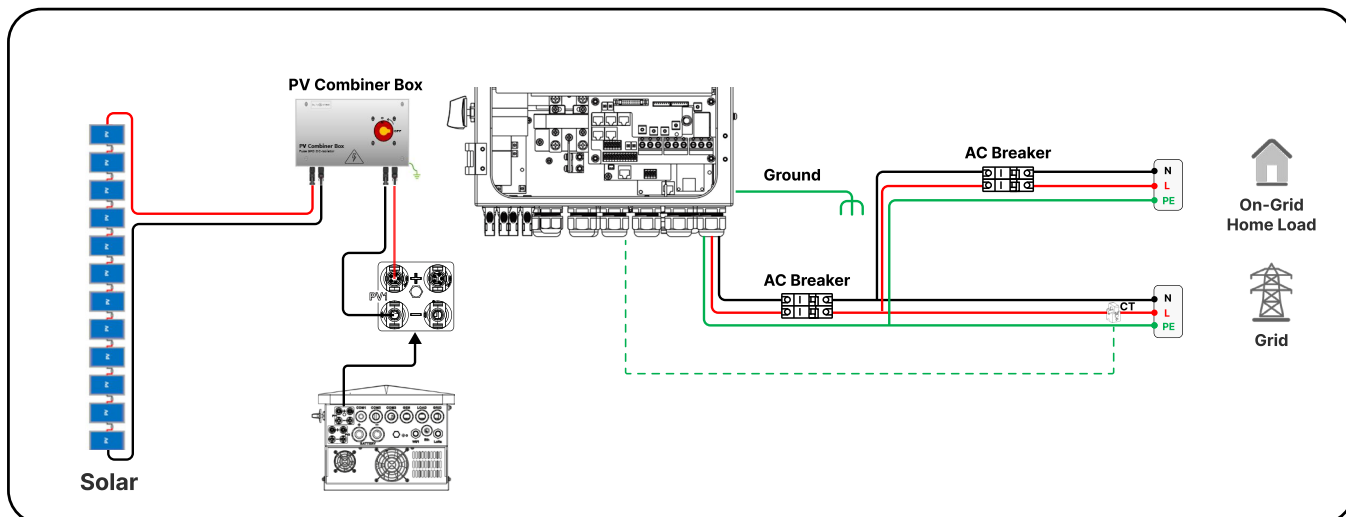

WARNING

The 1st priority power of the system is always the PV power, then 2nd and 3rd priority power will be the battery bank or grid according to the settings. The last power backup will be the Generator if it is available.

FAULT CODES

The Fault Codes page allows users to review historical fault events recorded by the inverter. Each entry displays a fault code, description, date, and time the fault occurred. This function is helpful for diagnosing system issues, especially when troubleshooting installation or runtime errors.

Fault Code			
F56	DC_VoltLow_Fault	2022-01-26	12:45
F56	DC_VoltLow_Fault	2022-01-24	11:00
F56	DC_VoltLow_Fault	2022-01-07	18:19
F56	DC_VoltLow_Fault	2022-01-08	01:58
F56	DC_VoltLow_Fault	2021-11-09	13:22
F56	DC_VoltLow_Fault	2021-11-03	17:48
F56	DC_VoltLow_Fault	2021-10-27	16:31
F56	DC_VoltLow_Fault	2021-10-20	19:17
Alarms Code	ID:000000000	Occurred	

What you can do from this page:

- View all recorded system faults in a list format.
- Check the fault code reference to understand the nature of the fault.
- Note the date and time to correlate events with grid conditions or system actions.
- Use the fault code to find troubleshooting steps in the technical manual (e.g. F56 = DC voltage too low).

If any of the fault messages listed in the following table appear on your inverter and the fault has not been removed after re-starting, please contact your local vendor or service centre. The following information is required:

- Inverter serial number.
- Distributor or service centre of the inverter.
- On-grid power generation date.
- The problem description (including the fault code and indicator status displayed on the LCD) with as much detail as possible.
- Owner's contact information.

In order to give you a clearer understanding of the inverter's fault information, we will list all possible fault codes and their descriptions when the inverter is not working properly.

Error Code	Description	Solutions
F08	GFDI_Relay_Failure	<ol style="list-style-type: none"> 1. When the inverter is in a Split phase (120/240Vac) or three-phase system (120/208Vac), the backup load port N line needs to connect ground. 2. If the fault still exists, please get in touch with Sunsynk for help.
F13	Working Mode Change	<p>Inverter work mode changed</p> <ol style="list-style-type: none"> 1. Reset the inverter. 2. Seek help from Sunsynk.
F18	AC over current fault or hardware	<p>AC Slide over current fault.</p> <ol style="list-style-type: none"> 1. Check if the backup load power is within the range of the inverter. 2. Restart, and check if it is normal.
F20	DC over current fault of the hardware	<p>DC side over current fault</p> <ol style="list-style-type: none"> 1. Check PV module connect and battery connect. 2. When in the off-grid mode, the inverter startup with a big power load, and it may report F20. Please reduce the load power connected. 3. Turn off the DC and AC switches, wait one minute, and then turn on the DC/AC switch again. 4. Seek help from Sunsynk if you can not return to a normal state.
F22	Tz_EmergStop_Fault	Please contact your installer for help.
F23	AC leakage current is trans over current	<p>Leakage current fault</p> <ol style="list-style-type: none"> 1. Check the PV module and inverter cables. 2. You may have a faulty PV panel (earth short). 3. Restart inverter.
F24	DC insulation impedance failure	<p>PV isolation resistance is too low</p> <ol style="list-style-type: none"> 1. Check if the connection of PV panels and inverter are firmly connected. 2. Check if the earth bond cable on inverters is connected to the ground.
F26	The bus bar is unbalanced	<ol style="list-style-type: none"> 1. Please wait 5 minutes to see if it returns to normal. 2. Fully reset the inverter.
F29	Parallel CANbus fault	<ol style="list-style-type: none"> 1. When in parallel mode, check the parallel communication cable connection and hybrid communication address settings. 2. During the parallel system startup period, inverters will report F29. When all inverters are in ON status, it will disappear automatically. 3. If the fault exists, please contact Sunsynk for help.
F34	AC Overcurrent fault	<ol style="list-style-type: none"> 1. Check the backup load connected, make sure it is in allowed power range. 2. If the fault still exists, please contact Sunsynk for help.

Error Code	Description	Solutions
F35	No AC grid	No utility 1. Please confirm grid is lost or not. 2. Check the grid connection. 3. Check the switch between inverter and grid in on or not. 4. If the fault still exists, please contact up for help.
F41	Parallel system stop	1. Check the hybrid inverter working status. If there's 1pcs hybrid inverter is in OFF status, the other hybrid inverters may report F41 fault in parallel system. 2. If the fault exists, please contact Sunsynk for help.
F42	AC line low voltage	Grid voltage fault 1. Check if the voltage is in the range of standard voltage in specification this can be adjusted via the grid set up page. 2. Check if grid cables are correctly connected.
F47	AC_OverFreq_Fault	Grid frequency out of range 1. Check if the frequency is in the range of specification. 2. You may need to adjust the frequency on the grid set up page.
F48	AC_UnderFreq_Fault	Grid frequency out of range 1. Check the frequency is in the range of specification or not. 2. Check whether AC cables are firmly and correctly connected. 3. Seek help from Sunsynk, if can not go back to normal state.
F56	DC bus bar voltage is too low	Battery low voltage 1. Check if the battery voltage is too low. 2. If the battery voltage is too low use the PV or grid to charge the battery. 3. Check the battery BMS. Important: Especially with Lithium batteries, ensure that the batteries Max. discharge current or power specification is the same or higher than the inverter specification.
F58	Battery_comm_Lose	1. It tells the communication between hybrid inverter and battery BMS disconnected when "BMS_Err-Stop" is active. 2. If don't want to see this happen, you can disable "BMS_Err-Stop" item on the LCD. 3. If the fault still exists, please contact Sunsynk for help.
F63	ARC_Fault	1. ARC fault detection is only for US market. 2. Check PV module cable connection and clear the fault. 3. Seek help from Sunsynk, if can not go back to normal state.
F64	Heat sink high-temperature failure	Heat Sink temp is too high 1. Check if the working environment temperature is too high. 2. Turn off the inverter for 30 minutes and restart.

Debug

The Debug Screen provides advanced real-time diagnostic data from the inverter. This screen is useful for technicians and experienced users to observe live system status, flags, and performance readings.

To access the Debug screen:

- On the inverter's front panel, press the following three buttons simultaneously → ESC + DOWN + ENTER

The Debug screen will appear showing various internal parameters.



Debug			
Genload_reverse_fg 000423	Gen.Start_fg 000000	Grid.inside.powerA 000000	Load_ab_avepower 000971
Working_mode 000014	Grid.Start_Relay 000000	Grid.inside.powerB 000000	BAT_CAP_CMP 000400
WakeUp_fg 020350	Bat_C_Rated 000000	Grid.outside.powerA 000000	Bat.Statue_Fg 004994
GFDIAD 004041	LLC_Curr 000005	Grid.outside.powerB 000000	WorkFG_onoffTrip 000000
Grid.Diff_Vol_LEAK 000041	EQUALISE_COUNT 000000	Grid.aveAB_rms 002303	INV_ON_OFF_AD 001567
Grid.ave_Volt_LEAK 002048	Grid.AVE_Vol_HV 000477	Grid.aveBC_rms 000000	ARCcount 005397
BatTarget_chargeV 005216	Grid.ave_Vol_busn 000002	Grid.aveCA_rms 000052	RealTimeSOC 000000

Please Quit

What You Can See on the Debug Screen:

- Live inverter flags and variables
- System operation statuses
- Voltage, power and frequency data
- Internal operational counters and state indicators



NOTICE

This screen is primarily intended for technical users. Most values are used for support diagnostics or firmware testing, and do not require user adjustment.

COMMISSIONING

Start-Up / Shutdown Procedure

The inverter must be installed by a qualified and licensed electrical engineer, following the relevant national wiring regulations. Prior to powering on, the installation engineer must complete the following checks:

- Earth bond test
- RCD (Residual Current Device) test
- Earth leakage tests
- Ensure the solar panel Voc voltage does not exceed 480V
- Verify battery voltage

Although the maximum allowable PV input voltage is 500V, the 480V limit provides an additional safety margin to protect the system from potential voltage fluctuations or operational variations that could cause damage.

Power ON Sequence:







- Switch on the AC.
- Press the start button.
- Switch on the battery and battery breaker.
- Switch on the DC (PV isolator).

Shutdown Sequence:

- Switch off the AC.
- Press the start button.
- Switch off the battery and battery breaker.
- Switch off the DC (PV isolator).

Inverter Commissioning Info

After you have successfully powered up the inverter, it must be programmed and set up as per the programming feature above.

 <p>Solar</p>	<p>Check each bond on the solar panels.</p>	<p>Check the VOC does not exceed 480V.</p>	<p>Ensure both MPPTs are balanced</p>
 <p>GRID</p>	<p>Measure the supply voltage check it matches the settings of the inverter.</p>	<p>If it falls out of the setting range it will cause the inverse shut down and alarm.</p>	<p>See Grid Setup page.</p>
 <p>BATTERY</p>	<p>Check the battery charge and discharge is within the C rating of the battery. Too high will damage the battery.</p>		<p>Check the battery BMS is communicating with the inverter.</p>
 <p>SYSTEM MODE</p>	<p>This is the heart of the system, this controls everything.</p>	<p>Ensure you are familiar with this, if you fully understand the controller you will fully appreciate the capabilities of there inverter.</p>	<p>See section 'Program Charge / Discharge Times'.</p>
 <p>ADVANCE</p>	<p>This is for paralleling systems, and wind turbine.</p>	<p>If paralleling inverters in 3 Phase check you phase rotation before switching on the AC Load, in 3 Phase the output voltage will increase across phase to 400V.</p>	<p>If using a wind turbine please ensure you have the correct limiting resistor, caps and rectifier.</p>
 <p>FAULT CODES</p>	<p>Familiarize yourself with common fault codes.</p>		

GDFI Fault

Before the inverter connects to the grid, it will check the impedance (effective resistance) of the solar PV+ to ground and the impedance of the solar PV- to ground. If either impedance value is found to be less than 33kΩ, the inverter will prevent grid connection and display an F24 error on the LCD. This is a safety feature designed to protect the system and ensure proper grounding.

MAINTENANCE

The inverter is designed to require minimal maintenance. However, to ensure optimal performance, it is important to follow these maintenance practices:

- **General Cleaning:** At least twice a year, and more frequently in dusty environments (weekly recommended), clean the cooling fans and air ducts to prevent dust accumulation. This will ensure proper ventilation and prevent overheating.

- Check Fault Codes: Regularly check the inverter’s display for any fault codes. If fault codes are present, they should be addressed immediately to ensure the system operates effectively.
- Lithium Battery Communication: Verify that communication with the Lithium battery is functioning correctly. This can be done through the inverter’s monitoring system or the battery management system (BMS).
- Weekly Cleaning: In environments with high dust accumulation or micro-ants, it is recommended to use micromesh filters. These filters can help keep dust, insects, and other particles out of the inverter’s internal components, preventing damage and ensuring proper airflow.

APPENDIX A

Definition of RJ45 Ports

No.	Color	RS485/CAN	Meter	DRM
1	Orange&White	485_B	Meter-485_B	DRM1/5
2	Orange	485_A	Meter-485_A	DRM2/6
3	Green&White	GND_485	-	DRM3/7
4	Blue	CAN-H	Meter-485_B	DRM4/8
5	Blue&White	CAN-L	Meter-485_A	REF-GEN/0
6	Green	GND_485	-	COM LOAD/0
7	Brown&White	485_A	Meter-485_A	Netj1_7
8	Brown	485_B	Meter-485_B	Netj1_7

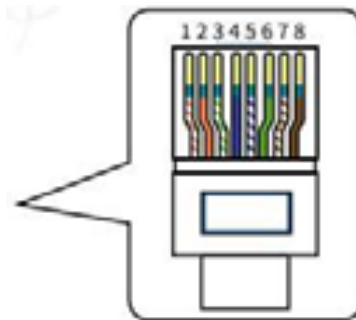

RS232

No.	WIFI/RS232
1	
2	TX
3	RX
4	
5	D-GND
6	
7	
8	
9	12Vdc

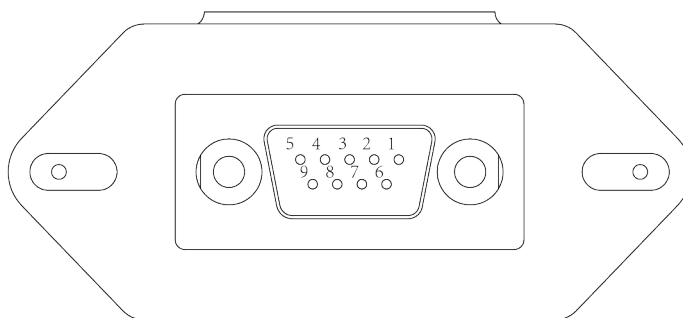

WIFI/RS232

This RS232 port is used to connect the wifi datalogger

APPENDIX B

Inverters sold in Australia will be set to the Default Australian standards, ensuring compliance with local regulations and grid compatibility.

APPENDIX C

The Sunsynk Single-Phase Hybrid Inverter is compatible with the Sunsynk Connect app via Wi-Fi or GSM data logger (see Sunsynk Connect instruction manual for setup details). This integration allows for remote monitoring and control of the inverter system, ensuring ease of use and real-time data access.

APPENDIX D

If an external Residual Current Device (RCD) is used, it should be a Type A/C with a tripping current of 30mA or higher.

Important Guidelines for Installing RCDs:

1. Disconnect all live conductors (including both active and neutral conductors).
2. Use the type specified in the inverter manufacturer's instructions or as labelled on the inverter.

We recommend the use of an RCD on all circuits and sub-circuits connected to the Sunsynk Inverter. Below are the recommended specifications for a Residual Current Breaker with Overcurrent Protection (RCDO).

Earth-leakage protection class	Type A
Earth-leakage sensitivity	30mA
Curve code	C
Network type	AC
Poles description	2P
Earth-leakage protection time delay	Instantaneous

APPENDIX E

The Sunsynk inverter can be connected to the internet, but a data logger must be added.

The inverter is compatible with Sunsynk Connect data-loggers, which you can obtain from your distributor.

Available types include:

- LAN-Type Data Logger
- Wi-Fi Type Data Logger
- GSM-Type Data Logger

To set up the internet connection for Sunsynk Connect, please refer to the App User instructions. The Data Logger should be connected to the bottom of the inverter via the connection socket marked WiFi.

For more information on training videos, software updates, help, and forum posts, please visit:

www.sunsynk.com - Tech Support

Follow Sunsynk on social media for updates:



Sunsynk



@energysolutions



SunsynkGroup



Contact Us

Call +44 151 832 4300 **Email** sales@sunsynk.com **Website** www.sunsynk.com

- Address**
- HK** Room 702-704, 7/F Texwood Plaza, 6 How Ming Street, Kwun Tong, Kowloon, Hong Kong
 - UK** Sunsynk UK Ltd, 17 Turnstone Business Park, Mulberry Avenue, Widnes, Cheshire, WA8 0WN
 - SA** Unit 2, 3 & 4, 80 Highview Blvd, Ferndale, Randburg, 2160, South Africa
 - NL** Sunsynk NL BV, Henri Wijnmalenweg 8, 5657 EP Eindhoven, Netherlands
 - AU** Level 1, 982-988 Wellington Street, West Perth WA 6005, Australia
 - ES** Tafetana, 32 P.I. Las Andoriñas 38639 Las Chafiras Santa Cruz de Tenerife
 - US** 100 S. Ashley Drive, Suite 600, Tampa, Florida, 33602, United States of America